

Enertech Air Handlers and Cased "A" Coils



Enertech air handler and "A" coil models are available for Enertech, GeoComfort, Hydron Module and TETCO brand systems. Consult the appropriate price book for specific model numbers, cross-matching, and additional product information. Visit enertechusa.com/products/air-handlers for installation manuals and product technical data.



To place an order, contact your distributor or Enertech customer service.
For further questions, contact your Territory Manager.

All Enertech indoor and outdoor split system models have AHRI (Air-Conditioning, Heating, and Refrigeration Institute) certified DX Air Handler and DX Cased "A" Coil matches for every model. That means better performance and guarantees the operating efficiency of the system, which is a requirement for many rebates and incentives.



DX Series, R410A, Multi-Position Air Handler

UNIT FEATURES

AHRI match with GeoComfort, Hydron Module, and TETCO split systems

6 sizes: 1.5 (018), 2 (024), 3 (036), 4 (048), 5 (060), and 6 (072) ton

Multi-Positional Applications (upflow, downflow, horizontal)

Variable Speed ECM Fan Motor

Factory Installed TXV (for cooling)

Factory installed 75VA Transformer with Circuit Breaker

All-Aluminum Air Coil

"Easy glide" slide out "A" Coil assembly for downflow applications

Easy to remove access panels

Easy to remove thermostat and control board "Snap Lock" mount

Closed cell insulated cabinet

Galvanized, pre-painted steel for quality and durability

Corrosion proof plastic drain pan with primary and secondary connections

"Easy glide" slide out blower assembly

Single-point Electrical Connection for Auxiliary Heat

2 piece cabinet - cased coil and blower

Modular Design allows flexibility when installing in tight spaces, which removes the need for home or building structure modifications

Optional "Plug-N-Play" Field Installed Electric Heater

Optional Filter Rack

5 Year Parts and 5 Year Service Labor Allowance warranty

Optional extended warranty options available



DX Series, R410A, Cased "A" Coil

UNIT FEATURES

AHRI match with GeoComfort, Hydron Module, and TETCO split systems

6 sizes: 1.5 (018), 2 (024), 3 (036), 4 (048), 5 (060), and 6 (072) ton

Multi-Positional Applications

Factory Installed TXV (for cooling)

All-Aluminum Air Coil

Galvanized, pre-painted steel for quality and durability

Corrosion proof plastic drain pan with primary and secondary connections

"Easy glide" slide out coil assembly

Closed cell insulated cabinet

5 Year Parts and 5 Year Service Labor Allowance warranty

Optional extended warranty options available

HYDRONIC AIR HANDLER & CASED "A" COIL

Enertech Hydronic Air Handlers and "A" Coils are a perfect fit for our line of water-to-water and air-to-water equipment. Now manufactured by Enertech, our Hydronic Air Handlers and "A" Coils come with the same high quality you can expect from the heat pumps you're pairing them with.

Hydronic Series, Multi-Position Air Handler

UNIT FEATURES

4 sizes: 2 (024), 3 (036), 4 (048), and 5 (060) ton	2 piece cabinet - cased coil and blower
Multi-Positional Applications (upflow, downflow, horizontal)	Modular Design allows flexibility when installing in tight spaces, which removes the need for home or building structure modifications
Variable Speed ECM Fan Motor	Optional "Plug-N-Play" Field Installed Electric Heater
Factory installed 75VA Transformer with Circuit Breaker	Optional Filter Rack
"Easy glide" slide out "A" Coil assembly for downflow applications	Single coil for both chilled water and hot water
Single-point Electrical Connection for Auxiliary Heat	Designed for 100°F to 120°F water in heating operation & 42°F to 50°F water in cooling operation
Easy to remove access panels	Optimized for use with Enertech geothermal branded water-to-water and air-to-water heat pumps
Easy to remove thermostat and control board "Snap Lock" mount	Copper sweat water connections
Galvanized, pre-painted steel for quality and durability	3 Year Parts Only Warranty and 90 Day Out-of-Box Assurance
Corrosion proof plastic drain pan with primary and secondary connections	Consult price book for additional warranty coverage details
"Easy glide" slide out blower assembly	
Closed cell insulated cabinet	



Hydronic Series, Cased "A" Coil

UNIT FEATURES

4 sizes: 2 (024), 3 (036), 4 (048), and 5 (060) ton	Single coil for both chilled water and hot water
Multi-Positional Applications	Optimized for use with Enertech geothermal brand water-to-water and air-to-water heat pumps
Galvanized, pre-painted steel for quality and durability	Corrosion-proof plastic drain pan with primary and secondary drain connections
Corrosion proof plastic drain pan with primary and secondary connections	Copper sweat water connections
"Easy glide" slide out coil assembly	3 Year Parts Only Warranty and 90 Day Out-of-Box Assurance
Closed cell insulated cabinet	Consult price book for additional warranty coverage details
Designed for 100°F to 120°F water in heating operation & 42°F to 50°F water in cooling operation	



DIMENSIONAL DATA

Cased "A" Coil

Series	Model	Size (Tons)	All Dimensions in Inches		
			A	B	C
DX	EED018	1.5	18.0	21.5	25.4
	EED024	2	18.0	21.5	25.4
	EED036	3	21.5	21.5	30.4
	EED048	4	21.5	21.5	30.4
	EED060	5	25.0	21.5	30.4
	EED072	6	25.0	21.5	30.4
Hydronic	EEH024	2	18.0	21.5	25.375
	EEH036	3	21.5	21.5	30.375
	EEH048	4	21.5	21.5	30.375
	EEH060	5	25.0	21.5	30.375

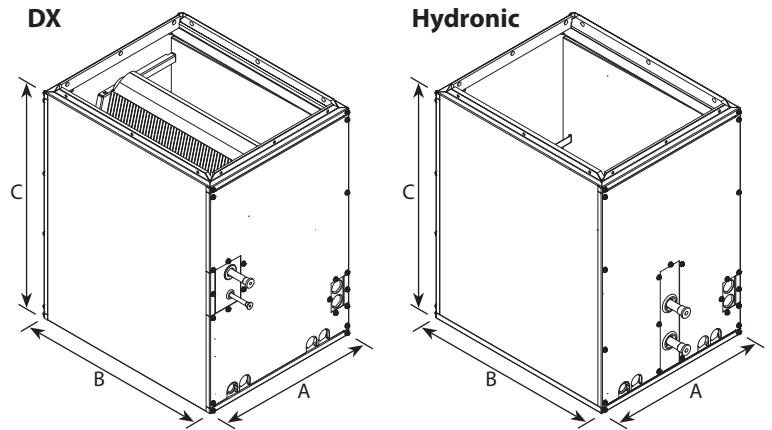

DX & Hydronic Air Handler

Series	Model	Size (tons)	All Dimensions in Inches			Return Air Opening	
			A	B	C	Width	Depth
DX	EAD018	1.5	18.0	21.5	47.0	20.0	16.5
	EAD024	2	18.0	21.5	47.0	20.0	16.5
	EAD036	3	21.5	21.5	53.6	20.0	20.0
	EAD048	4	21.5	21.5	53.6	20.0	20.0
	EAD060	5	25.0	21.5	53.6	20.0	20.0
	EAD072	6	25.0	21.5	53.6	20.0	20.0
Hydronic	EAH024	2	18.0	21.5	47.0	20.0	16.5
	EAH036	3	21.5	21.5	53.625	20.0	20.0
	EAH048	4	21.5	21.5	53.625	20.0	20.0
	EAH060	5	25.0	21.5	53.625	20.0	20.0

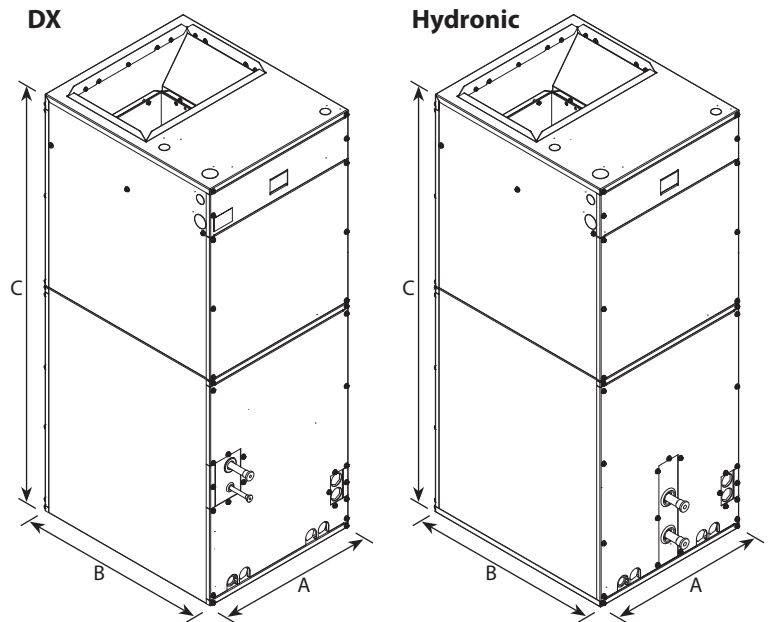

Enertech Global is continually working to improve its products. As a result, the design, specifications, and general information of each product may change without notice and may not be as described herein. For the most up-to-date information, please visit our website, or contact our Customer Relations department at customerrelations@enertechusa.com. Statements and other information contained herein are not express warranties and do not form the basis of any bargain between the parties, but are merely Enertech Global's opinion or commendation of its products.

