

# Installation and Operations Manual

RT MODELS OUTDOOR SPLIT SYSTEM WATER-TO-AIR HEAT PUMPS

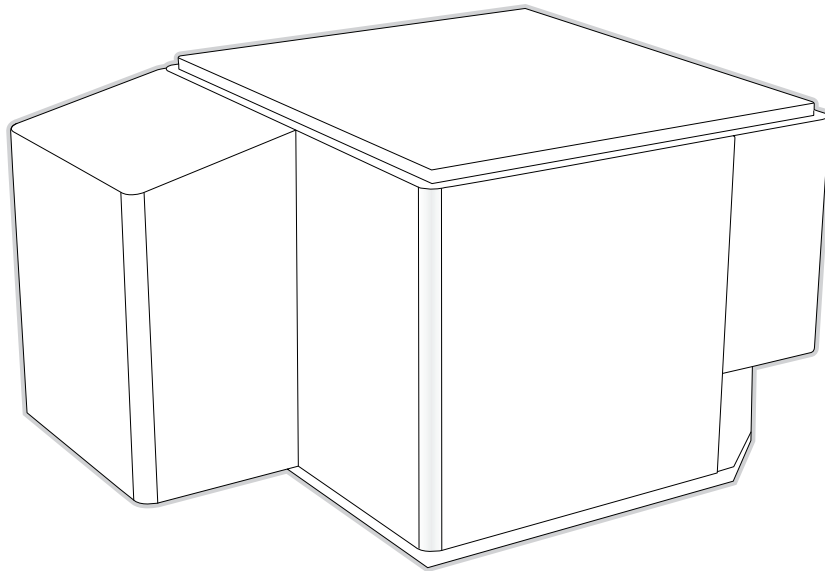

# Table of Contents

## Section 1: Model Nomenclature

Unit Nomenclature.....	4
------------------------	---

## Section 2: Installation Introduction

Introduction.....	4
Components .....	5
Pre-Installation Steps.....	5
Unit Top Cover Removal .....	6
Control Box Cover Removal.....	7
Flow Center Installation.....	7
Loop Connection .....	8
Loop Flushing .....	8

## Section 3: Unit Placement

Unit Wiring .....	10
Unit Assembly .....	10

## Section 4: Unit Data Information

Unit Dimensional and Physical Data.....	9
---	---

## Section 5: Filter Drier Installation

Installation.....	11
-------------------	----

## Section 6: Line Set Installation

Introduction.....	12
Definitions .....	12
Fittings and Components.....	12
Line Sets .....	13
Line Pressure Drop Table .....	14
Diagrams and Tables.....	15-22

## Section 7: Hot Water Generator Option

HWG Option Component Locations .....	23
HWG Option Component Locations .....	24

## Section 8: Unit Piping Installation

Water Quality .....	25
Antifreeze Overview .....	26-27

## Section 9: Controls

Microprocessor Features and Operation .....	28-29
Accessories .....	30

## Section 10: Wiring Diagram

Unit Wiring Diagram.....	31
--------------------------	----

## Section 11: Equipment Start-up

Equipment Start-Up Form .....	32
Equipment Start-Up Process Form .....	33

## Section 12: Troubleshooting

Pressure Drop and HE/HR Table(s) .....	34-37
Performance Check .....	38-48
Refrigeration Troubleshooting.....	49

## Section 13: Troubleshooting Form

Troubleshooting Form .....	50
----------------------------	----

## Section 14: Electrical Data

Unit Electrical Data.....	51
---------------------------	----

<b>Section 15: Specification Glossary &amp; Calculations</b>	
Glossary of Terms .....	51
Heating & Cooling Calculations .....	51
Water Flow Selection.....	52
<b>Section 16: Performance Data Correction Factors</b>	
Heating Correction Factors.....	53
Cooling Correction Factors .....	53
Sensible Cooling Correction Factors .....	53
<b>Section 17: Warranty Information/Forms and Revision Table</b>	
Warranty Registration Form .....	55
Revision Table.....	57

## Section 1: Model Nomenclature

### Unit Nomenclature

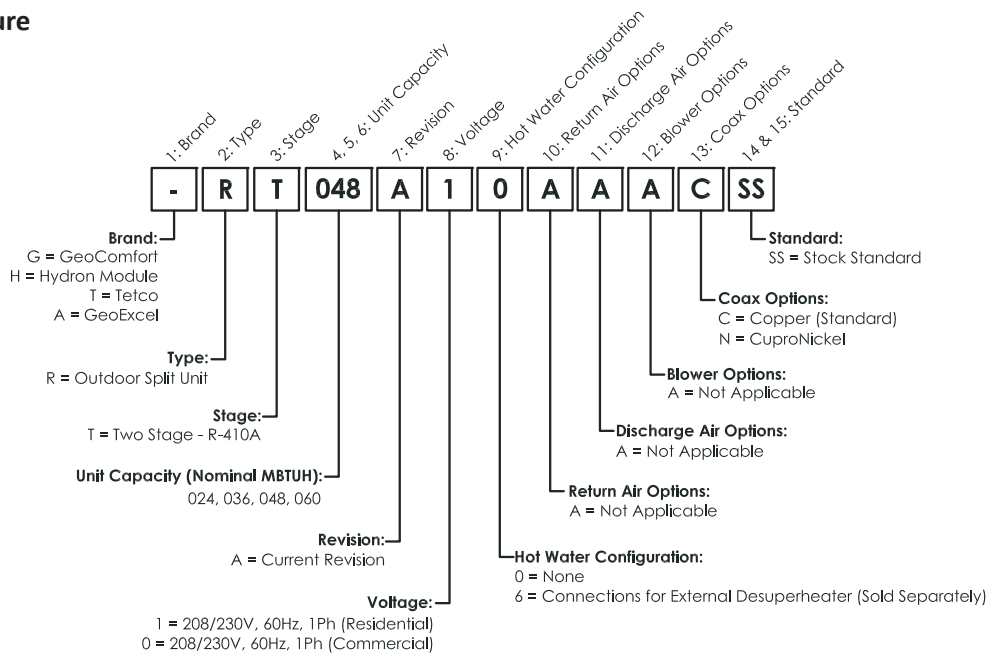

## Section 2: Installation Introduction

### Introduction

This geothermal heat pump provides forced air heating and cooling. Engineering and quality control is built into every geothermal unit. Good performance depends on proper application and correct installation.

### Notices, Cautions, Warnings, & Dangers

**“NOTICE”** Notification of installation, operation or maintenance information which is important, but which is NOT hazard-related.

**“CAUTION”** Indicates a potentially hazardous situation or an unsafe practice which, if not avoided, COULD result in minor or moderate injury or product or property damage.

**“WARNING”** Indicates potentially hazardous situation which, if not avoided, COULD result in death or serious injury.

**“DANGER”** Indicates an immediate hazardous situation which, if not avoided, WILL result in death or serious injury.

### Inspection

Upon receipt of any geothermal equipment, carefully check the shipment against the packing slip and the freight company bill of lading. Verify that all units and packages have been received. Inspect the packaging of each package and each unit for damages. Insure that the carrier makes proper notation of all damages or shortage on all bill of lading papers. Concealed damage should be reported to the freight company within 15 days. If not filed within 15 days the freight company can deny all claims.

**Note:** Notify Enertech Global’s shipping department of all damages within 15 days. It is the responsibility of the purchaser to file all necessary claims with the freight company.

### Unit Protection

Protect units from damage and contamination due to plastering (spraying), painting and all other foreign materials that may be used at the job site. Keep all units covered on the job site with either the original packaging or equivalent protective covering. Cap or recap unit connections and all piping until unit is installed. Precautions must be taken to avoid physical damage and contamination which may prevent proper start-up and may result in costly equipment repair.

**⚠ CAUTION ⚠**  
DO NOT OPERATE THE GEOTHERMAL HEAT PUMP UNIT DURING BUILDING CONSTRUCTION PHASE

### Storage

All geothermal units should be stored inside in the original packaging in a clean, dry location. Units should be stored in an upright position at all times. Units should not be stacked unless specially noted on the packaging.

**⚠ WARNING ⚠**  
FAILURE TO FOLLOW THIS CAUTION MAY RESULT IN PERSONAL INJURY. USE CARE AND WEAR APPROPRIATE PROTECTIVE CLOTHING, SAFETY GLASSES AND PROTECTIVE GLOVES WHEN SERVICING UNIT AND HANDLING PARTS.

## Section 2: Installation Introduction

**Consumer Instructions:** Dealer should instruct the consumer in proper operation, maintenance, filter replacements, thermostat and indicator lights. Also provide the consumer with the manufacturer's Owner's Manual for the equipment being installed.

**Enertech Global D-I-Y Policy:** Enertech Global's geothermal heat pumps and system installations may include electrical, refrigerant and/or water connections. Federal, state and local codes and regulations apply to various aspects of the installation. Improperly installed equipment can lead to equipment failure and health/safety concerns. For these reasons, only qualified technicians should install a Enertech Global built geothermal system.

Because of the importance of proper installation, Enertech Global does not sell equipment direct to homeowners. Internet websites and HVAC outlets may allow for purchases directly by homeowners and do-it-yourselfers, but Enertech Global offers no warranty on equipment that is purchased via the internet or installed by persons without proper training.

Enertech Global has set forth this policy to ensure installations of Enertech Global geothermal systems are done safely and properly. The use of well-trained, qualified technicians helps ensure that your system provides many years of comfort and savings.

**Equipment Installation:** Special care should be taken in locating the unit. Installation location should include adequate service clearance around the unit. All units should be placed on a formed plastic air pad, or a high density pad slightly larger than the base of the unit.

**Electrical:** All wiring, line and low voltage, should comply with the manufacturer's recommendations, The National Electrical Code, and all local codes and ordinances.

**Thermostat:** Thermostats should be installed approximately 54 inches off the floor on an inside wall in the return air pattern and where they are not in direct sunlight at anytime.

**Loop Pumping Modules:** Must be wired to the heat pump's electric control box. A special wiring whip is provided to connect the Pump Module wiring.

### Components

**Master Contactor:** Energizes Compressor and optional Hydronic Pump package.

**Logic Board:** Logic Board operates the compressor and protects unit by locking out when safety switches are engaged. It also provides fault indicator(s).

**Terminal Strip:** Provides connection to the thermostat or other accessories to the low voltage circuit.

**Transformer:** Converts incoming (source) voltage to 24V AC.

**Low Voltage Breaker:** Attached directly to transformer, protects the transformer and low voltage circuit.

**Reversing Valve:** Controls the cycle of the refrigerant system (heating or cooling). Energized in cooling mode.

**High Pressure Switch:** Protects the refrigerant system from high refrigerant pressure, by locking unit out if pressure exceeds setting.

**Low Pressure Switch:** Protects the refrigerant system from low suction pressure, if suction pressure falls below setting.

**Flow Switch (Freeze Protection Device):** Protects the water heat exchanger from freezing, by shutting down compressor if water flow decreases.

**Compressor:** Pumps refrigerant through the heat exchangers and pressurizes the refrigerant, which increases the temperature of the refrigerant.

**Desuperheater Option:** Internal valves and piping allowing connection and charging of an external Desuperheater (Supplied by others)

### Pre-Installation

Special care should be taken in locating the geothermal unit. Installation location chosen should include adequate service clearance around the unit.

### Pre-Installation Steps:

1. Compare the electrical data on the unit nameplate with packing slip and ordering information to verify that the correct unit has been shipped.
2. Inspect all electrical connections and wires. Connections must be clean and tight at the terminals, and wires should not touch any sharp edges or copper pipe.
3. Verify that all refrigerant tubing is free of dents and kinks. Refrigerant tubing should not be touching other unit components.
4. Before unit start-up, read all manuals and become familiar with unit components and operation. Thoroughly check the unit before operating.
5. Verify that all components of the system will have adequate service access.
6. Make sure that all applicable wiring, ductwork, piping, and accessories are correct and on the job site.
7. Verify that the air handler or "A" coil selected for the system is the correct AHRI match for the selected outdoor unit.
8. Unpack all components of the outdoor installation kit, which is located in a separate box shipped with the unit. The kit should contain the following.
  - Flow Center Cover
  - Aluminum Pipe Shield
  - Pre-Assembled Hose Kit with P/T Ports
  - Pump Wiring Harness
  - PE 90° Street Elbows(Shown with field provided piping)



## Section 2: Installation Introduction

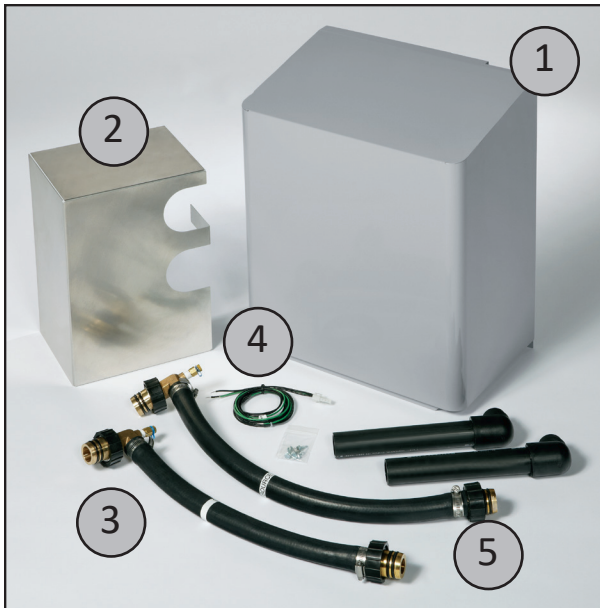

### ⚠ CAUTION ⚠

BEFORE DRILLING OR DRIVING ANY SCREWS INTO CABINET, CHECK TO BE SURE THE SCREW WILL NOT HIT ANY INTERNAL PARTS OR REFRIGERANT LINES.

### Site Preparation

First, survey the installation site to determine the best location for placing the outdoor unit. The outdoor unit must be installed no closer than 9 inches from the outdoor walls of the facility.

Ground level installations must be located according to local codes or ordinances. A suitable mounting pad must be used and it must be separate from the building foundation. The pad must be level and strong enough to support the weight of the unit. The pad height must be a minimum of 2 inches above grade and with adequate drainage.

An electrical disconnect must be located within sight of the unit and readily accessible. The electrical disconnect shall be capable of electrically de-energizing the outdoor unit. All electrical connections must be made in accordance with all applicable codes and ordinances. See electrical data tables for correct wire and fuse sizing.

### Unit Preparation

Carefully remove all unit packaging and pallet fasteners that are located on two corners of the unit. Again inspect the unit for any damage to the cabinet or service valves.

### Unit Placement/Lifting Unit

Once the site is ready for unit placement, the compressor section can be moved by lifting from the bottom of the unit. Do not lift the unit by placing your hand under the control box section, or by using the snow load bars, this could deform the unit and cause damage.

Once the unit is in-place, and oriented for both line set and loop connections, remove both the top cover and the control box cover.

### Unit Top Cover Removal

To remove the unit top cover, remove the two screws on the front end of the top cover. Once the screws are removed, pull the lid slightly up, and then forward to disengage the rear retainer clips. Take care not to lift directly up as you may warp the retainer clips and cause the cover to not seat properly.

### Example 1: Outdoor Unit Placement



### Example 2: Outdoor Unit Placement



## Section 2: Installation Introduction

### Control Box Cover Removal

To remove the control box cover, remove the four screws on both sides of the cover. The control box cover is designed to be removed whether the unit top cover is installed or not. However, if the unit top cover is installed, it might be slightly difficult to remove due to the gasketing that protects the control box from moisture. Take care with removal or replacement to not damage this gasketing.

### Flow Center Installation

Once the unit is in-place, and the unit cover and control box cover is removed, the flow center can now be installed

The flow center is installed on the outside of the unit and is designed to hang over the unit pad. It is necessary to rotate the flow center to keep the flush valves between the loop and the pumps. Before installing the flow center, the pump(s) will need to be rotated on the flow center where the electrical box is in the upward direction (Figure 1). Failure to reorientate the pumps could lead to condensation entering the electrical box of the pump potentially causing unit damage. Once the pumps are rotated, the flow center can be attached to the cabinet with four provided screws.

After the flow center is mounted on the unit, the provided wire harness which connects the flow center to the control section can be attached (Figure 2).

Once the pumps are wired and connected, install the provided hose kit to connect the flow center to the unit. The hoses are clearly labeled loop in and loop out. The hose kits are designed so that the 90° elbows with the PT ports are installed on the flow center side. All models utilize double o-ring fittings for hose kit connection. Make sure all connections are solid and retainer rings are secure and hand tight.

### Freeze Sensor

A built-in freeze protection system energizes the flow center pumps to circulate the loop fluid when the cabinet temperature is below 22°F. The pumps are disengaged when the cabinet temperatures is above 32°F. (The switch has a tolerance of +/- 3°F)

Figure 1: Flow Center Installation

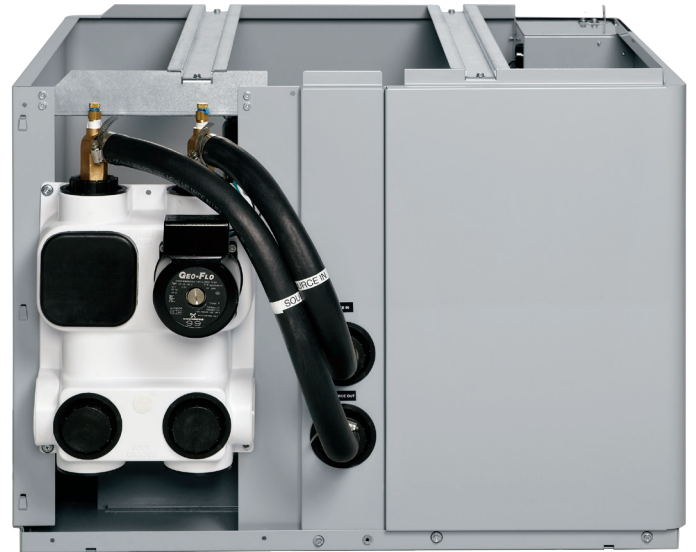
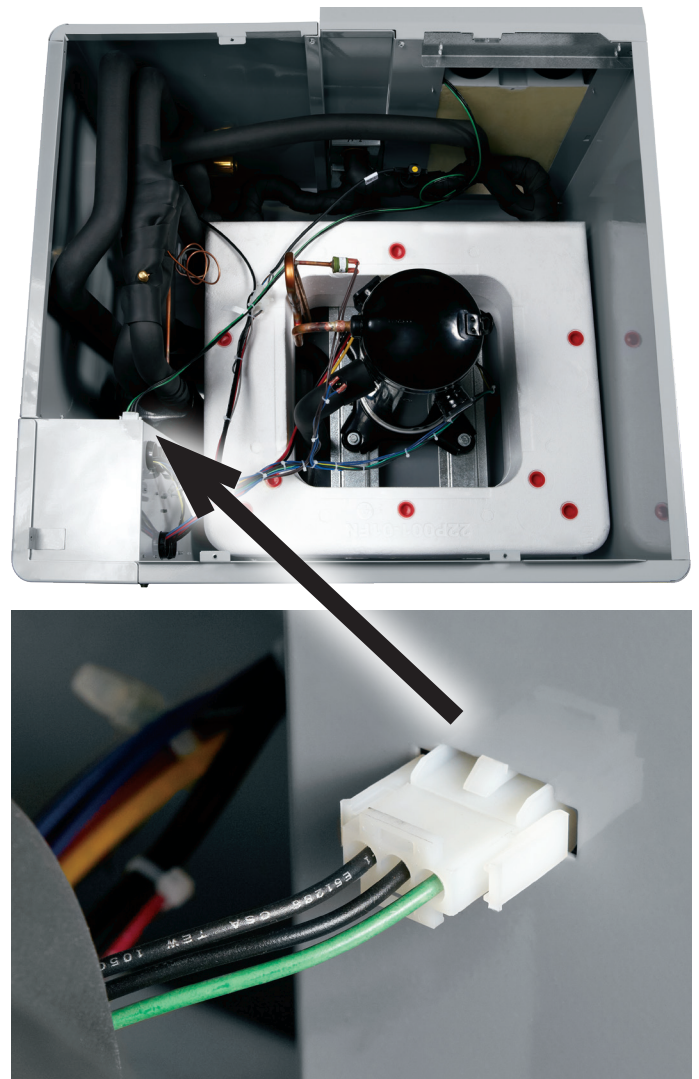

Figure 2: Flow Center Wiring





## Section 2: Installation Introduction

### Loop Connection

The RT is designed around making loop connection easy. Once the flow center is in-place, it's time to bring the loop to the unit.

After the loop has been installed and headered, the supply and return lines should be trenched to the side of the unit where the flow center is located. At this point, you have a couple of options on connecting the loop to the flow center.

#### Option 1:

The loop can be brought directly into the bottom of the flow center using the double o-ring to PE fusion fitting included with the flow center (Figure 3). This might be slightly difficult depending on how much play you have with the piping and area to work in.

#### Option 2:

The loop can be brought at an angle into the bottom of the flow center. Included with the installation kit are 2 90° PE elbows. These should be fused to the double o-ring to PE fusion fitting included with the flow center. From there, you can use an extension of PE pipe and another 90° elbow to make the final connection. The aluminum pipe shield and outdoor cover have been designed with extra room to accommodate this option (Figure 4). If this option is installed above grade, the total assembly cannot exceed 9" to fit inside the pipe shield.

### Loop Flushing

Once all loop and unit piping is completed, flush and fill the loop using normal procedures outlined in the Loop & Flow Center AOM (PN# 2323-0027-001. See the water quality and antifreeze overview and charging sections in this document for additional information.

Figure 3: Straight Loop Connection

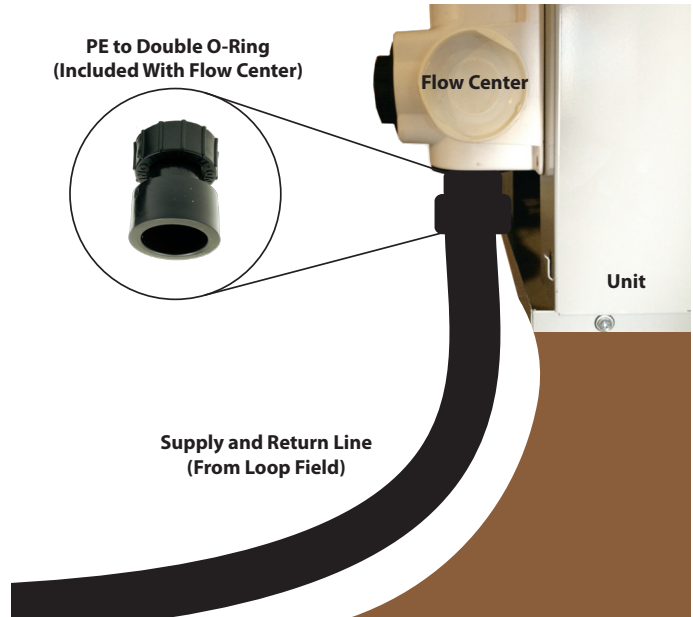
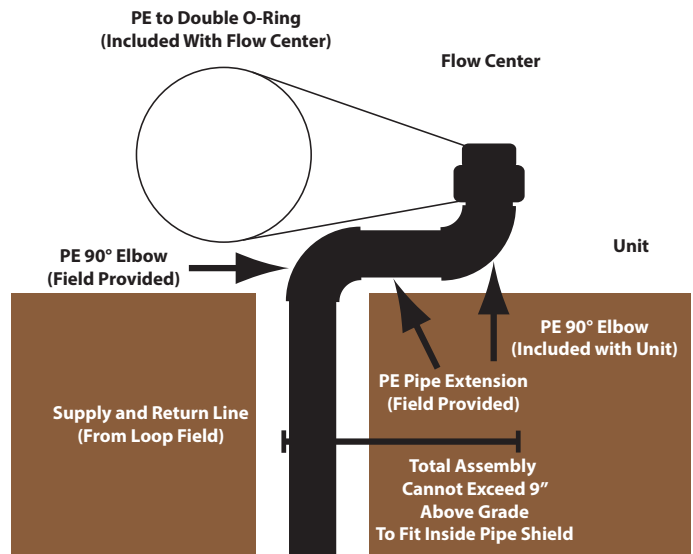

Figure 4: Angled Loop Connection



### Pipe Shield

Once the loop installation is completed, the pipe shield can be installed. This aluminum shield will protect the loop lines from damage.

To install the shield, you may have to clear out a small amount of dirt around the loop piping. The shield had notches and a guide for proper placement. The goal is to have the shield slightly buried to insure proper protection.



## Section 3: Installation Considerations

### Unit Wiring

Line voltage to the unit should be supplied from a dedicated branch circuit containing the correct fuse or circuit breaker for the unit. The outdoor unit requires both power and control circuit electrical connections. All electrical connections must be in accordance with all applicable codes and ordinances.

Line voltage to the unit must be protected and brought into the unit through the bottom of the control box (see fig. 5). Wires should be attached to the L1 and L2 terminals of the contactor, and to ground. See electrical data tables for correct wire and fuse sizing for each unit.

### Unit Assembly

Once the following installation items are completed, use the Unit Startup form in this manual to begin final unit startup.

1. Flow center installed, loop field connected, hose kit connection, unit and loop field flushed and filled.
2. Line and low voltage wiring completed.
3. Line set installed at the unit and at the air handler or "A" coil.
4. Unit fully charged and ready for operation.

Once the final startup has been completed and the unit is operating properly, replace all panels and covers in the following order.

1. **Flow center cover.** The flow center cover locks into place with clips on the left side and screws along the top to secure the cover to the unit. The cover should fit over the aluminum pipe shield.
2. **Control Box Cover.** The control box cover secures to the cabinet with four screws.
3. **Top Unit Cover.** Place the unit cover clip first onto the back of the unit. Keeping the cover at about a 10° angle to the top of the unit, slide the cover back to engage the clips. Once the clips are engaged, lower the lid down and replace the two front screws to finish securing the lid.

### Line Set Installation

The RT model features angled backseating service valves (see fig. 6) for line set installation. See Section 4c for proper procedures for installation of the line set and unit charging.

Figure 5: Control Box

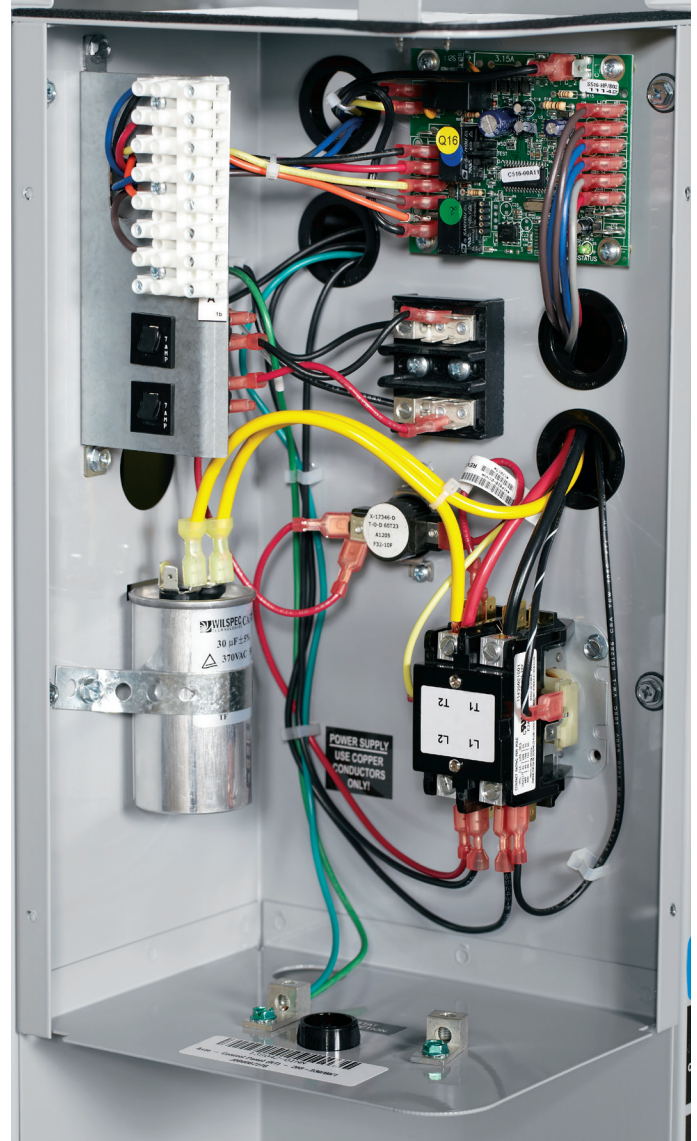
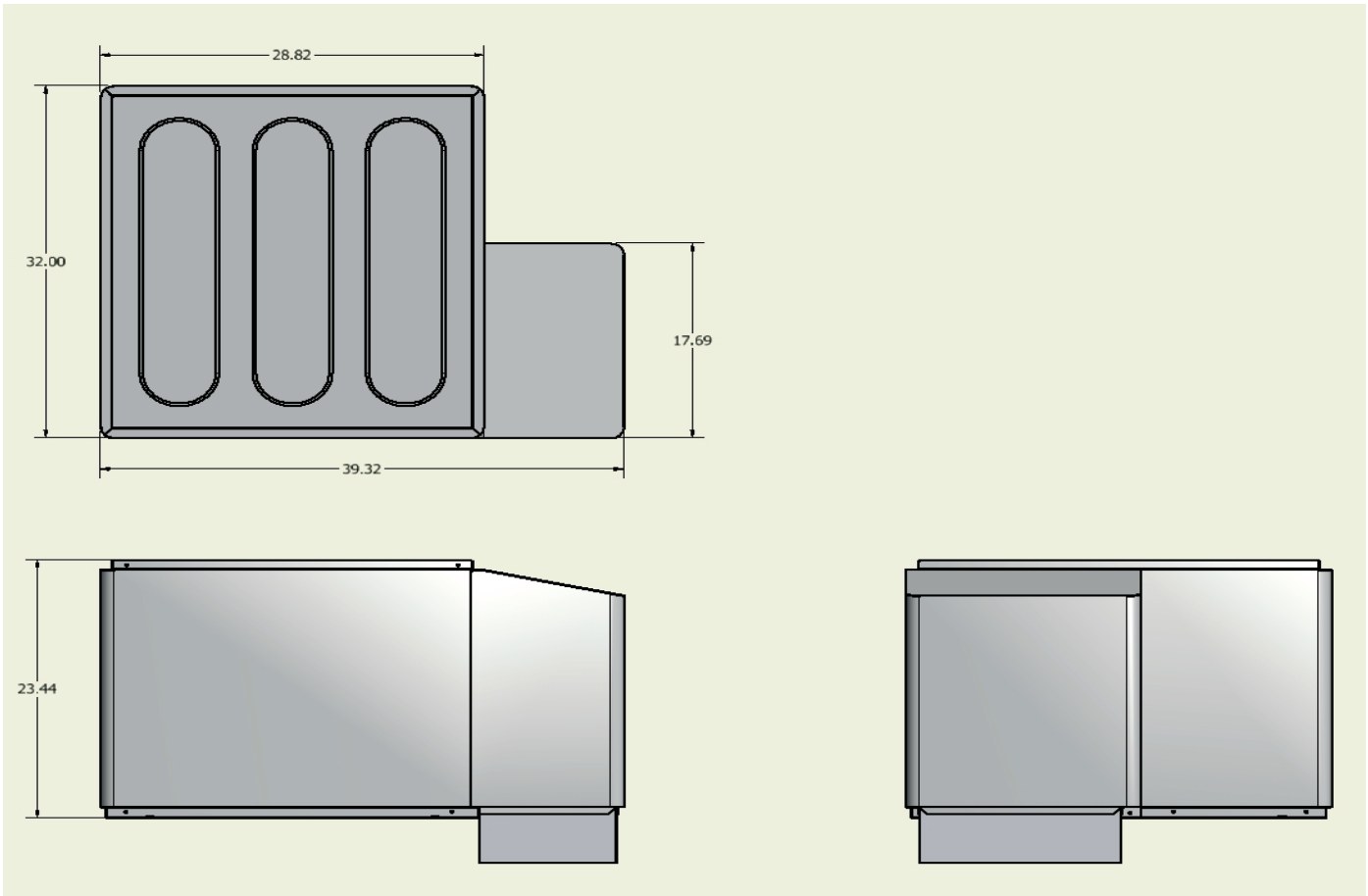

Figure 6: Service Valves



## Section 4: Unit Data

### Unit Dimensional and Physical Data



Model	Dimensional Data			Refrigeration Connection		Water Loop*		Unit Weight (Pounds)
	Height	Width	Depth	Liquid	Suction	IN	OUT	
024	23.4	32.0	28.8	3/8"	7/8"	1" Double O-Ring		180
036	23.4	32.0	28.8	3/8"	7/8"			225
048	23.4	32.0	28.8	3/8"	7/8"			270
060	23.4	32.0	28.8	1/2"	1-1/8"			270

### AHRI Air Handler and "A" Coil Matches

Compressor Section	Air Handler Match	"A" Coil Match
024	EAD024	EED024
036	EAD036	EED036
048	EAD048	EED048
060	EAD060	EED060

## Section 5: Filter Drier Installation

### Installation

A reversible heat pump filter drier must be installed on the liquid line near the cabinet of the compressor section. A filter drier is furnished with the unit. The filter drier kit includes a 3" piece of 1/2" or 5/8" copper tubing. This tubing will fit either inside or on the outside of the stub coming off the liquid line service valve. Braze it in place. Then braze the filter drier onto it.

A second piece of copper is attached between the filter drier and the liquid line (not needed for all applications, depending upon line set size -- consult line set sizing chart).

Refer to the air handler IOM for details on line set and unit installation. Always use dry nitrogen when brazing.

**Table 1: Recommended Line Set Sizes**

Model	Unit Refrigerant Connections		Recommended Liquid & Suction Line Size			
			20 Feet		50 Feet	
	Liquid Line (OD)	Suction Line (OD)	Liquid Line (OD)	Suction Line (OD)	Liquid Line (OD)	Suction Line (OD)
024	3/8"	7/8"	1/2"	3/4"***	Two-stage unit's line sizes should not be increased due to reduced pumping capacity in first stage.	
036	3/8"	7/8"	1/2"	7/8"		
048	3/8"	7/8"	1/2"	1-1/8"		
060	1/2"	1-1/8"	1/2"	1-1/8"		

40°F Evaporating Temperature

\*Suction line is not sized large in two-stage units due to the lower velocity of first stage operation.

\*\*Reduce from 7/8" unit connection to 3/4" suction line for proper velocity

Weight of refrigerant in copper lines per 10 feet	
Liquid Line Size (OD)	Oz. Per 10 Feet
3/8"	5.4
1/2"	10.4
5/8"	19.5

**Figure 7: Filter Drier Installation**

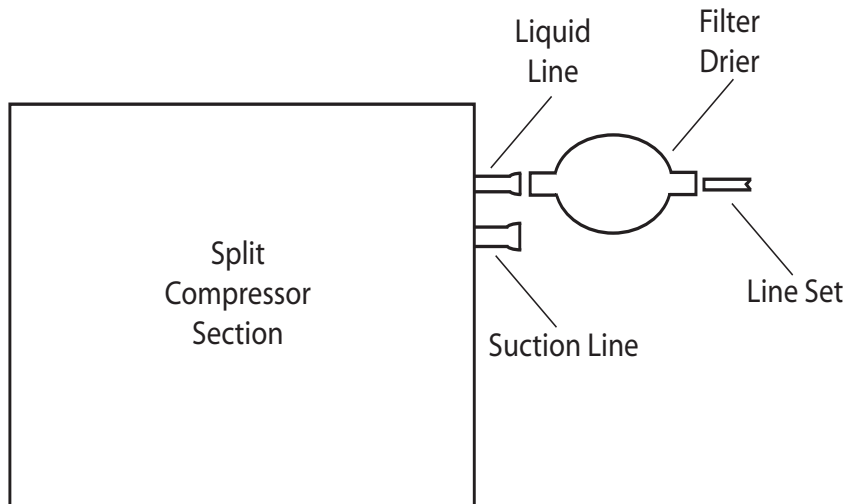

## Section 6: Line Set Installation

### Introduction

The purpose of this section is to help in the design of refrigeration line sets on geothermal heat pump systems. The three considerations when designing a refrigerant piping system are as follows:

- 1. System Reliability:** Poor Oil Management may shorten the life of the compressor. Proper liquid refrigerant control is essential.
- 2. System Performance:** Pressure drop in refrigerant lines tends to decrease capacity and increase power consumption. High velocities can increase sound levels. Modulation often depends on proper piping.
- 3. Cost:** Level of refrigerant, copper piping, accessories, and labor used will impact the applied cost.

### Definitions

Long line set applications are defined as any line set that includes 50 feet or more of interconnecting tubing or a vertical distance between the evaporator and compressor sections exceeding 20 feet.

### Line Set Requirements/Limitations

#### Line Set Limitations

Up to 50 equivalent feet: Use rated line sizes listed in unit installation instructions.

50 - 75 equivalent feet or 20 feet of vertical separation: Bi-flow liquid line solenoid and crankcase heater required (refer to figures 12-15 on pages 24-27).

#### Maximum Piping Lengths

Maximum equivalent length = 75 feet  
 Maximum linear length = 50 feet  
 Maximum linear liquid lift = 50 feet  
 Maximum linear vapor rise = 50 feet (Single Speed)/25 feet (Two Stage)

#### Fittings and Components

All piping should be "ACR" or "L" type copper pipe. Long radius fittings should always be used unless there is not enough physical space. Pressure drop due to friction in pipe, fittings and field installed accessories such as a drier, solenoid valve or other devices should be considered (see Table 2). The pressure drop due to friction is usually smaller than pressure drop due to lift. The pressure drop ratings of field installed devices are usually supplied by the manufacturer of the device and should be used if available.

### Equivalent Length

Valves, fittings, and bends create more friction pressure drop than straight copper piping. Find the equivalent feet of straight tubing for each fitting for calculations. This allows for a quick calculation of the total equivalent length (see Example 1). The equivalent length of copper tubing for commonly used fittings, valves, and filter-drier are shown in Table 2.

#### **Total Equivalent Length = Linear Feet of Straight Tubing + Fitting Losses in Equivalent Feet**

Example 1: A 3-ton unit with 7/8" vapor tubing has 50 linear feet of straight tubing. The total number of elbows includes three long radius 90° elbows and five standard 90° elbows.

50ft. of straight tubing  
 + 4 standard 90° elbows X 2 equiv ft  
 +1 liquid line solenoid X 12 equiv ft  
 +1 filter-drier X 6 equiv ft  
 = 50ft. + 8ft. + 12ft. + 6ft.  
 = 76 ft. total equivalent length

**Table 2: Copper Fittings in Equivalent Length**

Tube Size O.D. (in.)	90° Std A	90° Long Radius - B	45° Std C	45° Long Radius
3/8"	1.2	0.8	0.5	0.3
1/2"	1.3	0.9	0.6	0.4
5/8"	1.6	1.0	0.8	0.5
3/4"	1.8	1.2	0.9	0.6
7/8"	2.0	1.4	1.0	0.7
1-1/8"	2.6	1.7	1.3	0.9
Liquid Line Solenoid	12			
Filter	6			

## Section 6: Line Set Installation

### Line Sets

#### Vapor Line

A long line set application can critically increase the charge level needed for a system. As a result, the system is very prone to refrigerant migration during its off-cycle. A crankcase heater and bi-flow liquid line solenoid will help minimize this risk. A crankcase heater and bi-flow liquid line solenoid is recommended for any line set over 50 feet in equivalent length or 20 feet of vertical separation. Because oil separates from the refrigerant in the evaporator, the vapor line velocity must be adequate to carry the oil along with the refrigerant. Horizontal vapor lines require a minimum of 800 fpm velocity for oil entrainment. Vapor risers require 1200 fpm minimum, and preferably 1500 fpm regardless of the length of the riser.

**Note:** When a two-stage compressor section is located above the indoor coil, the maximum vertical rise of a vapor line must not exceed 25 feet. This limit is due to velocity requirements for oil entrainment in the vapor riser.

For example, a 4 ton unit producing 48,000 Btuh with a 7/8" vapor line has a velocity of 1500 fpm (See Figure 9). On first stage the compressor runs at 67% or 32,680 Btuh and has a velocity of less than 1200 fpm per the pressure drop chart. In order to achieve velocity up to 1500 fpm in first stage, the line would have to be 3/4". The pressure drop for 48,000 Btuh would be over 9 psi. A system will lose approximately 1% capacity for every pound of pressure drop due to friction in the suction line. This 1% factor is used to estimate the capacity loss of refrigerant lines. Due to the low velocities created in the vapor line in first stage, a two stage unit vapor line should not be increased from the pipe size at the compressor section.

For all vapor line trapping see Figure 8. Remember to add all the fittings into the total equivalent length of the vapor line.

#### Liquid Line

Pressure drop due to vertical liquid lift must be considered. The pressure drop for vertical lift is 0.43 pound per foot for R-410A. This is usually large and may be a limiting factor in the ultimate design of the system. Next, the pressure entering the expansion device must be sufficient to produce the required flow through the expansion device. A pressure drop of 175 psi for R-410A across the expansion valve and distributor is necessary to produce full refrigerant flow at rated capacity. Therefore, it is necessary for liquid refrigerant (free of flash gas) to be delivered to the expansion valve. Longer line sets may require a larger liquid line due to the higher pressure drops of smaller diameter tubing. Reference the Installation Manual for recommended liquid line sizes for each unit. Even liquid lines on two stage units can be increased because velocities required for oil return are not critical in the liquid line.

Figure 8: Oil Trap Construction

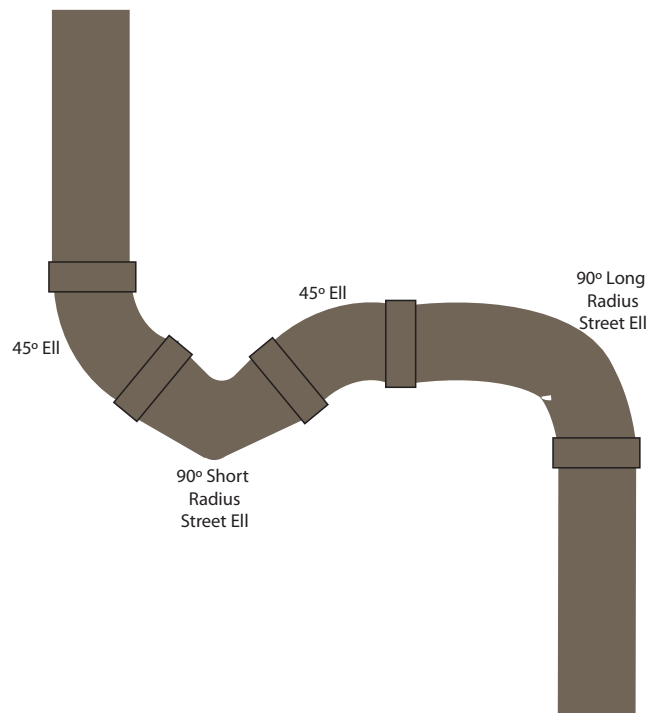



## Section 6: Line Set Installation

### Line Pressure Drop Table

Figure 9: Refrigerant R-410A Suction Line Pressure Drop/Velocity per 100 ft. of Line at 45°F Evaporating Temperature and 125°F Condensing Temperature

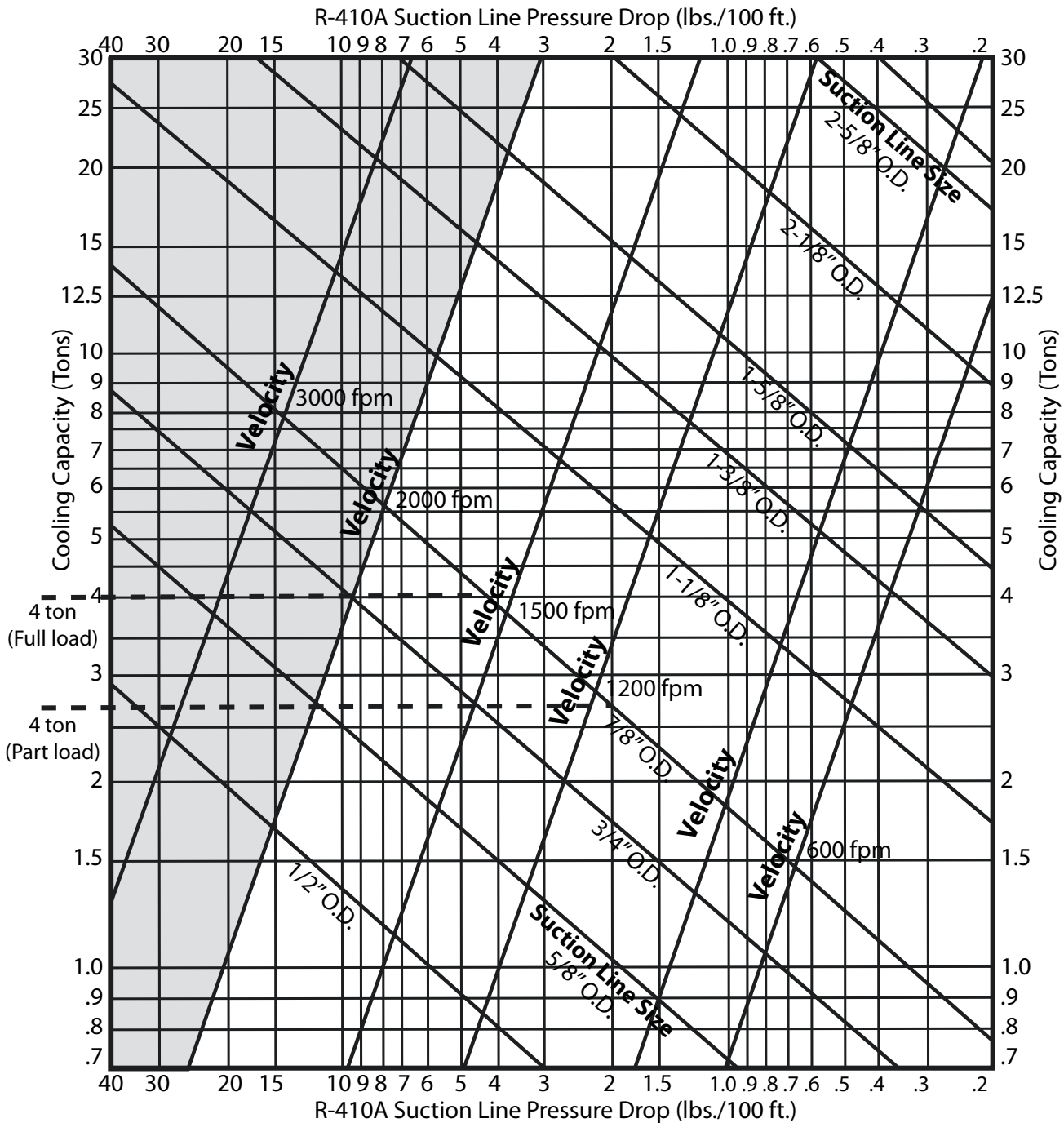

To use this chart, first find capacity (tons) on the left side of the chart. To find pipe size, proceed right to the smallest pipe size. Pressure drop (vertical line) and velocity (diagonal lines) can then be determined for the pipe size selected. For example, for a 4 ton unit, select 7/8" O.D. line.

NOTE: Shaded area denotes unacceptable velocity range.

## Section 6: Line Set Installation

### Geothermal Refrigeration Circuits

#### Bi-Flow Liquid Line Solenoid Valve

In order to minimize off-cycle refrigerant migration to the compressor, a bi-flow liquid line solenoid is required for all long line set heat pump applications. The Bi-flow solenoid valve controls the flow of refrigerant only in the direction of the arrow molded into the valve. The bi-flow liquid line solenoid valve is shipped as a single flow valve, the carton contains another valve stem which needs to be installed in the valve to convert it to a bi-flow valve. The bi-flow valve should be connected to the 24V side of the contactor. When installing the valve, **the arrow should be positioned toward the compressor section** to minimize the transfer of liquid directly into the coax in the heating mode. The solenoid should be installed right after the filter-drier or within two feet of the compressor section.

#### Charging Information

Since the lengths of line sets vary, it is necessary to calculate additional refrigerant charge. Compressor sections do not have additional charge for the line set. Each foot of liquid line and vapor length requires the amount of refrigerant designated in Table 3. Also, long line applications require a minimum of 10 degrees subcooling to prevent any refrigerant flashing before the thermostatic expansion valve. The subcooling and superheat should be checked in both modes of operation. Refer to the operating pressure chart in the Specifications manual for the correct superheat.

### Piping Diagrams

The piping diagrams on the following pages illustrate considerations for applications of a solenoid valve, traps, and piping based upon the location of the compressor section and air handler.

**Table 3: Refrigerant Weight**

Weight of Refrigerant in Copper Tubing Per Foot (in Ounces)		
O.D. (in.)	Liquid Line	Suction (Vapor) Line
3/8"	0.54	
1/2"	1.04	
5/8"	1.95	0.07
3/4"		0.10
7/8"		0.13
1-1/8"		0.21

## Section 6: Line Set Installation

### Split System Charging - Approach Method

Charging Enertech split systems can easily be accomplished by measuring approach temperatures when operating in the cooling mode. This method, outlined in the steps below, is based upon testing in Enertech's R & D labs with matched compressor/air handler or A-coil components. For best results, the indoor temperature should be between 70°F and 85°F in cooling. Charging the unit in cooling is the most accurate method. If unable to charge the unit in cooling mode, refer to the next section, "Split System Charging -- Subcooling/Superheat Method." Refer to figure 6 for temperature and pressure measurement locations when using the approach method.

**Please Note:** Before utilizing the approach method for checking the system charge, confirm the system reaches a minimum of 2°F subcooling, while maintaining a maximum of 22°F superheat. If you are not able to achieve these readings, further troubleshooting will be required (Reference Table 12 in Section 9, Refrigeration Troubleshooting). Consult the Refrigeration/Troubleshooting manual for a review of Superheat/Subcooling calculations.

1. If the entering water temperature is above 45°F and the entering air temperature is above 70°F, the unit should be charged in cooling for the most accurate results. If the return air temperature is below 70°F, it may be necessary to run the system in emergency heating mode to raise the indoor temperature above 70°F.
2. Evacuate the line set and A-coil. Open the service valves, and monitor the system pressures while charging. Model 024 is charged with 36oz; model 036 is charged with 56oz; and models 048 - 072 are charged with 80oz. This factory charge is a "starting" supply. Charge will need to be added for the line set and heat exchangers. However, do not add charge until the unit has run for at least five minutes, and the subcooling is above 2°F (see step #3).
3. The approach temperatures will not be usable if there is not a liquid lock at the liquid line (i.e. there is some subcooling at the liquid line). Record the liquid line pressure and the saturation temperature (most gauge sets show saturation temperature on the gauge). Measure the liquid line temperature. If the liquid line is not at least 2°F cooler than the liquid line saturation temperature, there may not be a liquid lock. Continue to add charge until subcooling reaches at least 2°F. Then, proceed to step #4.
4. Measure the water flow rate and entering water temperature (EWT). Measure the liquid line temperature (using the same digital thermometer if possible).
5. Subtract the EWT from the liquid line temperature (LLT) to determine approach temperature (Approach temperature = LLT - EWT).
6. Compare the result to Table 4. If the approach temperature is too high, add charge; if it's too low, recover charge. Approach temperature should be within 1°F of the table value.

### Split System Charging - Subcooling/Superheat Method

If checking charge in the heating mode (**preferred charging mode is cooling**), follow the steps below. For best results, the indoor temperature should be between 60°F and 70°F in heating. If the return air temperature is below 60°F, it may be necessary to run the system in emergency heating mode to raise the indoor temperature above 60°F. Refer to figure 7 for temperature and pressure measurement locations when using the Subcooling/Superheat method.

1. Evacuate the line set and A-coil. Open the service valves, and monitor the system pressures while charging. The compressor section is charged for the compressor section and air handler/A-coil only (except model 024, which includes about 65% of this charge for manufacturing process reasons). Charge will need to be added for the line set (and heat exchangers for model 024). However, do not add charge until the unit has run for at least five minutes, and the subcooling is above 2°F (see step #2).
2. The system will not be stable if there is not a liquid lock at the liquid line (i.e. there is some subcooling at the liquid line). Record the liquid line pressure and the saturation temperature (most gauge sets show saturation temperature on the gauge). Measure the liquid line temperature at the air handler. If the liquid line is not at least 2°F cooler than the liquid line saturation temperature (i.e. 2°F Subcooling), there may not be a liquid lock. Continue to add charge until subcooling reaches at least 2°F. Then, proceed to step #3.
3. Record the suction pressure and the saturation temperature (most gauge sets show saturation temperature on the gauge). Measure the suction line temperature. If the suction line temperature is more than 15°F higher than the saturation temperature (i.e. 15°F Superheat), the unit is undercharged.
4. Continue to add charge to the unit, comparing the Superheat/Subcooling results to Table 5. Stop adding charge when the Superheat/Subcooling values are within range. Each time the refrigerant charge is adjusted, allow at least five minutes run time for the system to stabilize.

## Section 6: Line Set Installation

**Table 4: Approach Temperatures-Cooling Mode\***  
Full Load Operation

Water Flow GPM/ton	Entering Water Temp., deg F	Entering Air DB Temp., deg F	Approach Temp. by Model, deg. F Full Load			
			024	036	048	060
1.5	45	70 - 85	6	5	18	8
	55		6	6	15	7
	65		5	5	12	5
	75		4	4	9	3
	85		3	3	6	2
2.25	55	70 - 85	4	2	13	4
	65		4	3	10	4
	75		3	3	7	3
	85		2	2	5	1
	95		1	2	2	1
3.0	55	70 - 85	3	1	11	3
	65		3	2	9	3
	75		2	2	6	2
	85		1	2	4	1
	95		1	1	2	1

\*Cooling approach temperature = Liquid Line temp - Entering Water temp  
(should be within +/- 1 deg F)

**Figure 10: Cooling Mode -- Temperature & Pressure Measurement Locations**

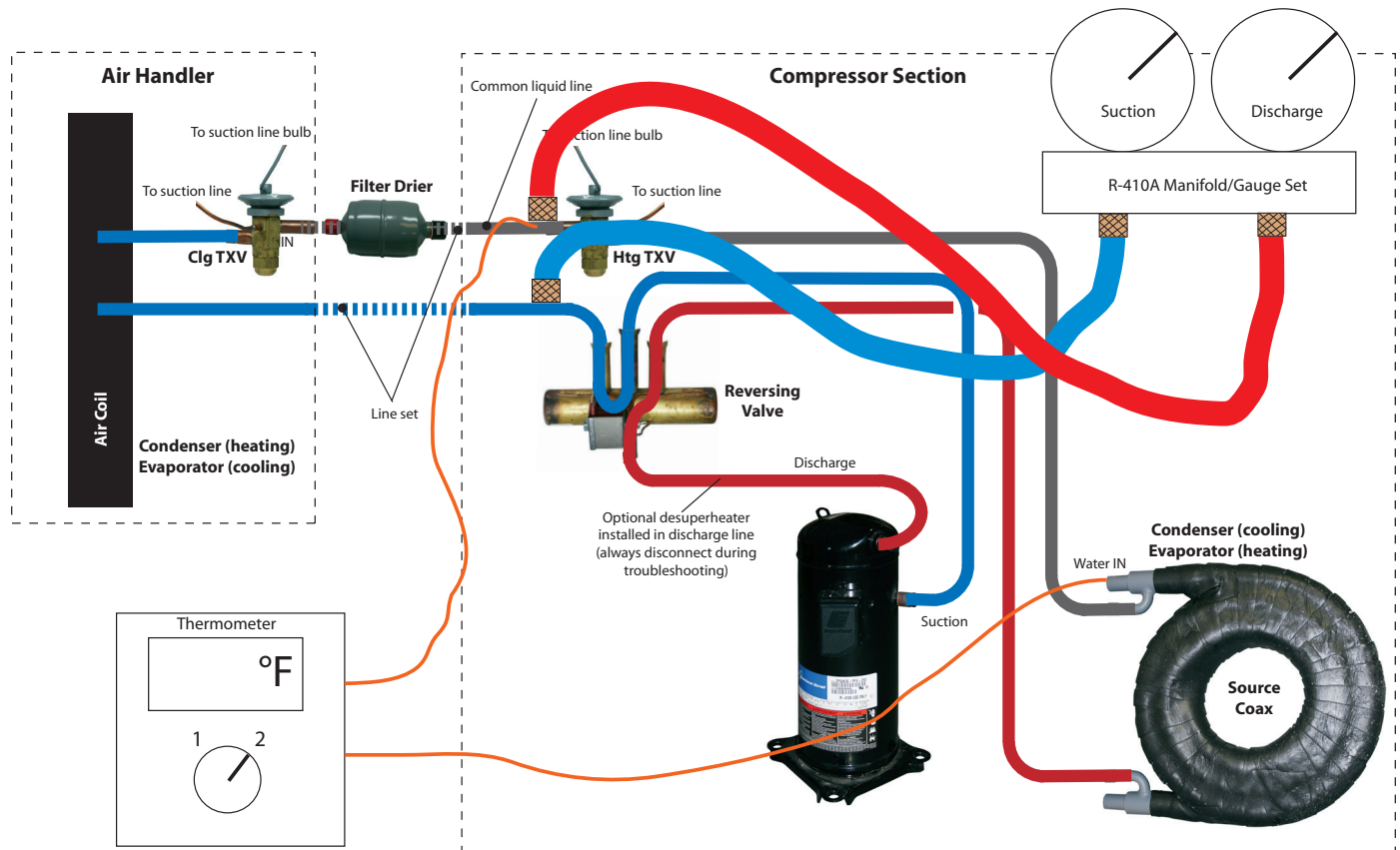

**NOTE: Check water flow via pressure drop method (pressurized systems) or flow meter tool (non-pressurized systems). Compare water flow to chart in Table 2.**

## Section 6: Line Set Installation

**Table 5: Subcooling/Superheat-Heating Mode\***  
Full Load Operation

Model	Entering Water Temp., deg. F	Entering Air Temp., deg. F	Subcooling	Superheat
024	32	60 - 70	3 - 5	8 - 10
	40		2 - 4	9 - 11
	50		2 - 4	9 - 11
036	32	60 - 70	7 - 9	5 - 7
	40		7 - 9	5 - 7
	50		7 - 9	5 - 7
048	32	60 - 70	4 - 6	6 - 8
	40		4 - 6	7 - 9
	50		4 - 6	9 - 11
060	32	60 - 70	2 - 4	4 - 6
	40		3 - 5	5 - 7
	50		6 - 8	5 - 7

\*Valid for flow rates between 1.5 and 3 GPM/ton.

**Figure 11: Heating Mode -- Temperature & Pressure Measurement Locations**

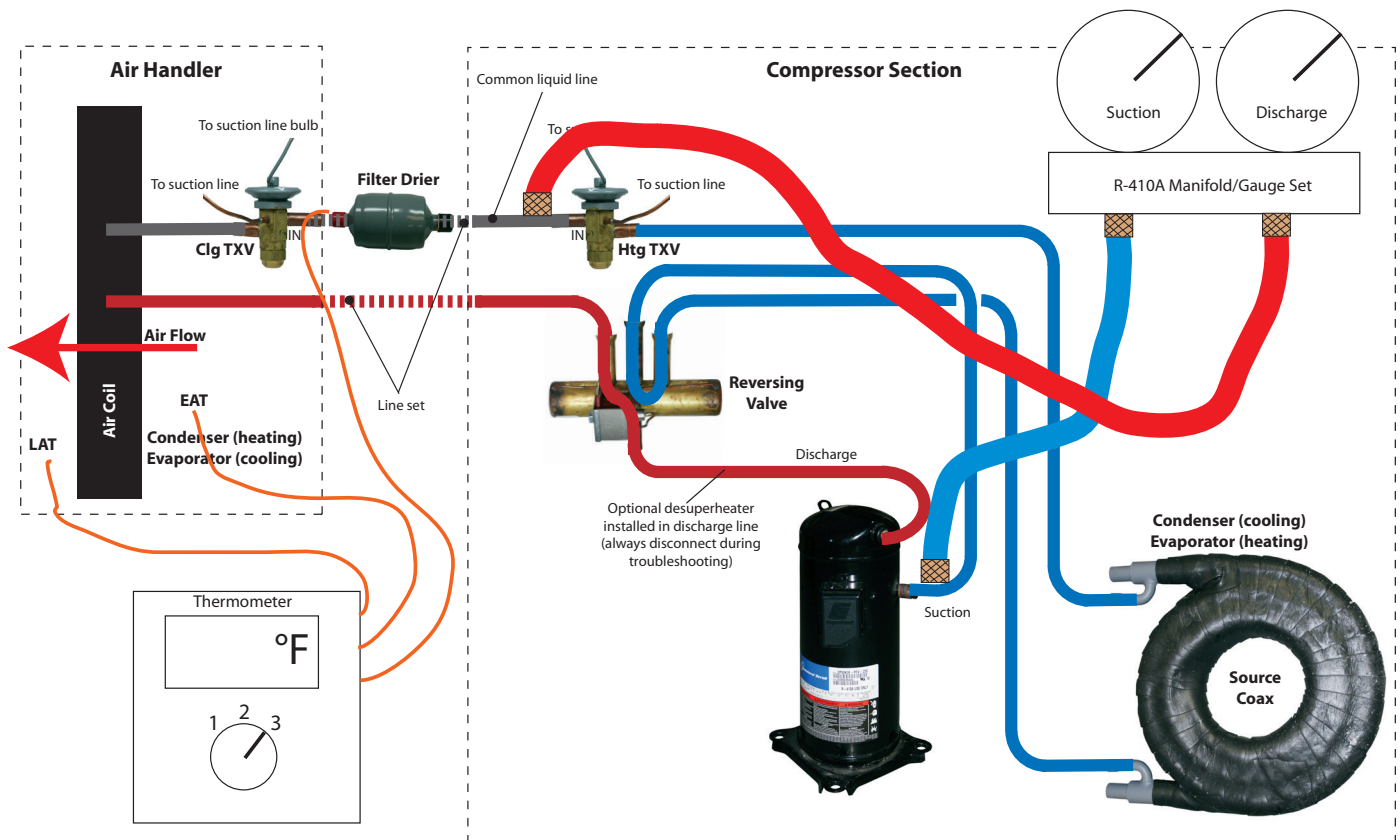



## Section 6: Line Set Installation

Figure 12: Air handler section above compressor section

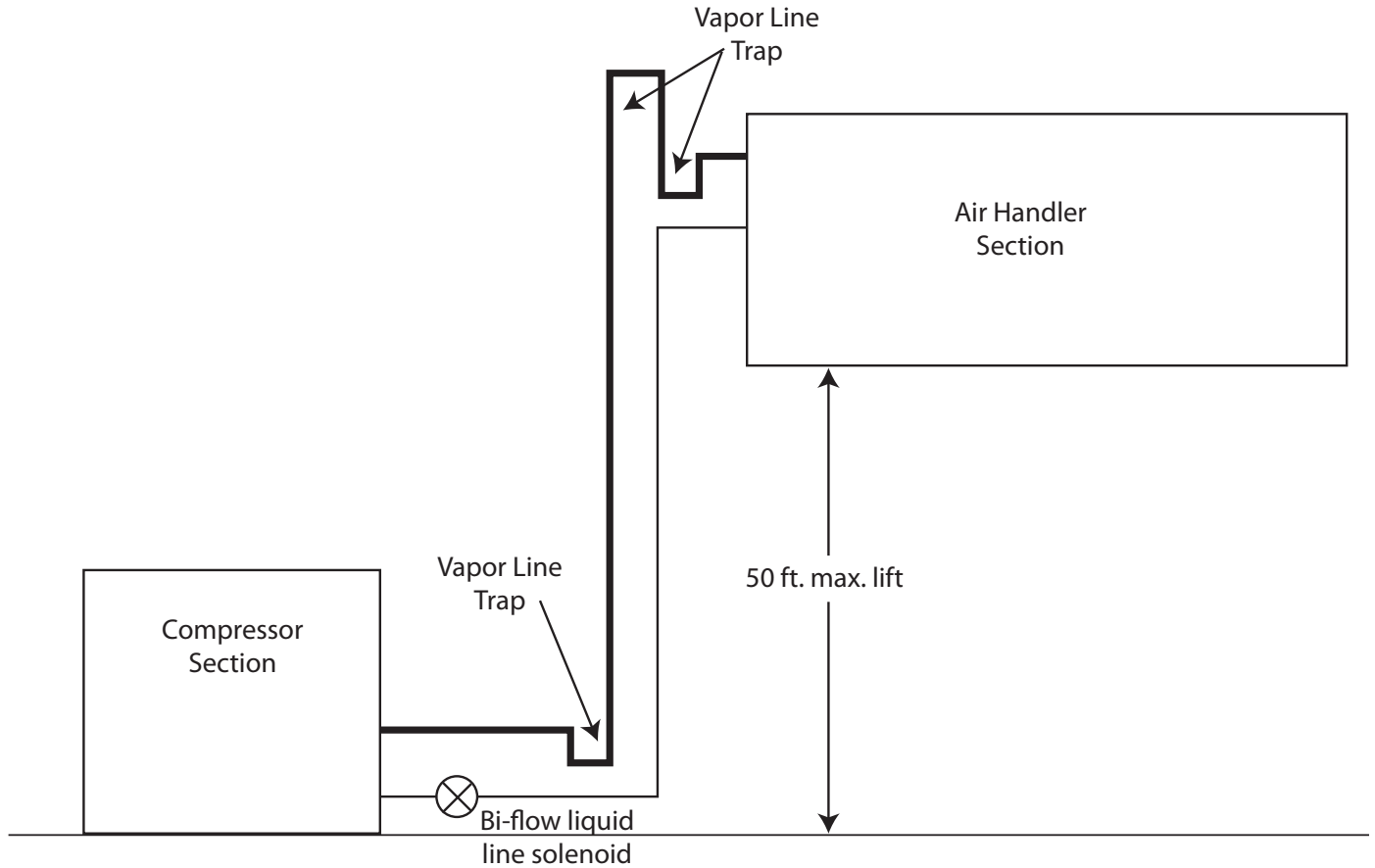

### Notes:

- A Bi-flow liquid line solenoid required if total equivalent length is greater than or equal to 50 feet or the vertical separation is greater than or equal to 20 feet. See tables below for descriptions and part numbers.
- An inverted vapor line trap must be installed with the top of the trap above the evaporator section.
- P-traps should be installed at the outlet of the evaporator section and at the bottom of vapor line drop.
- 75 feet maximum equivalent line length
- 50 feet maximum vertical separation
- Vapor Line sizes on Two-stage units should not be increased due to the velocity requirements for returning oil to the compressor.

Bi-flow Solenoid Data		
Compatible Models	Description	Part Number
All Split Models (24-60)	1/2" Valve Body	ARS-4B
	24V Coil	ARSCB
Only required in long line set applications. All three parts must be ordered.		

## Section 6: Line Set Installation

Figure 13: Compressor section above air handler section

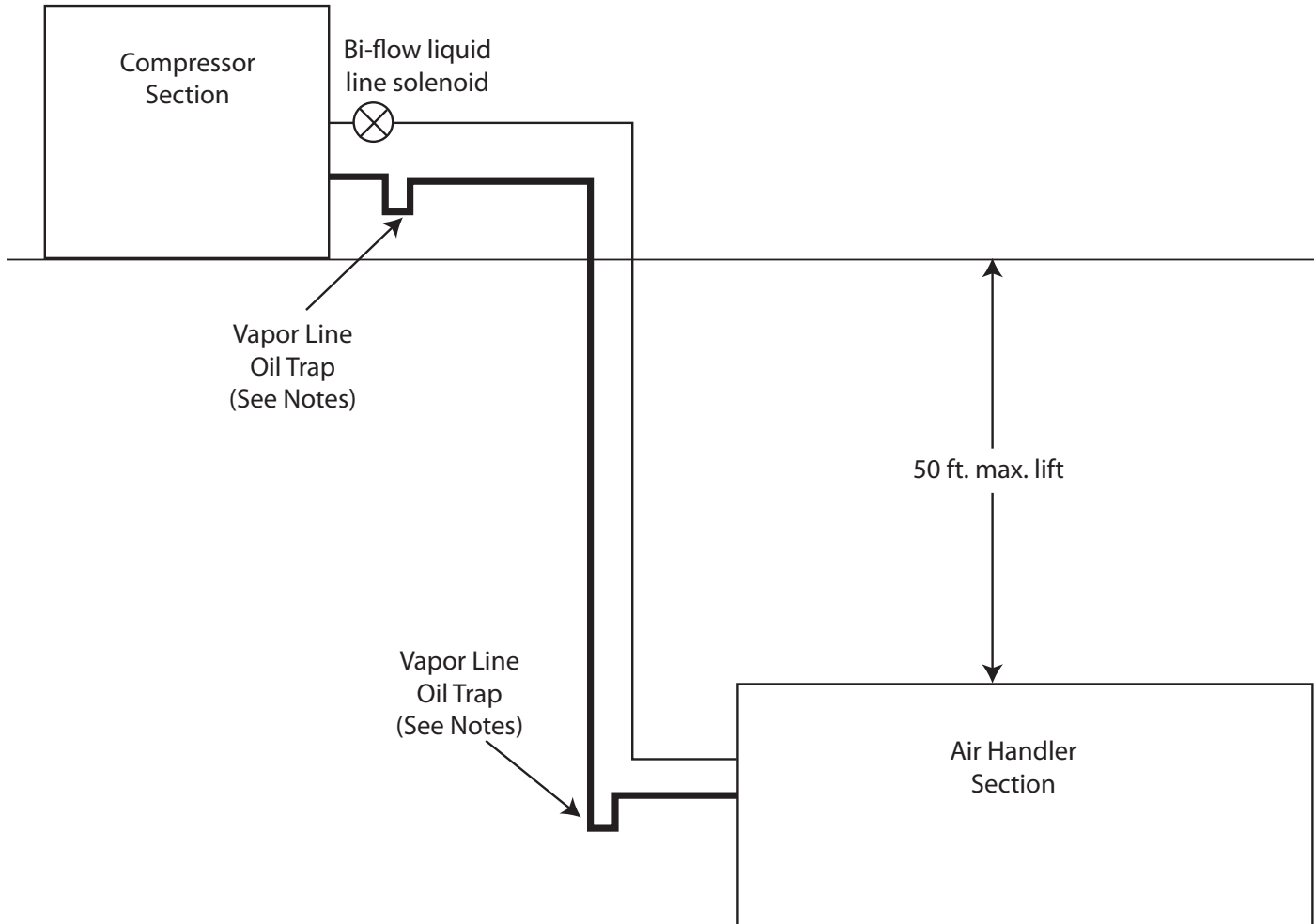

### Notes:

- A Bi-flow liquid line solenoid required if total equivalent length is greater than or equal to 50 feet or the vertical separation is greater than or equal to 20 feet. See tables below for descriptions and part numbers.
- A P-trap should be installed at the outlet of the evaporator section.
- If vertical separation is greater than or equal to 50 feet a second trap should be installed at the 50 feet mark.
- 75 feet maximum equivalent line length
- 50 feet maximum vertical separation.
- Vapor Line sizes on Two-stage units should not be increased due to the velocity requirements for returning oil to the compressor.
- Two-stage units should have a maximum of 25 feet of vertical lift on the vapor line.

Bi-flow Solenoid Data		
Compatible Models	Description	Part Number
All Split Models (24-60)	1/2" Valve Body	ARS-4B
	24V Coil	ARSCB
Only required in long line set applications. All three parts must be ordered.		

## Section 6: Line Set Installation

Figure 14: Horizontal piping above air handler section

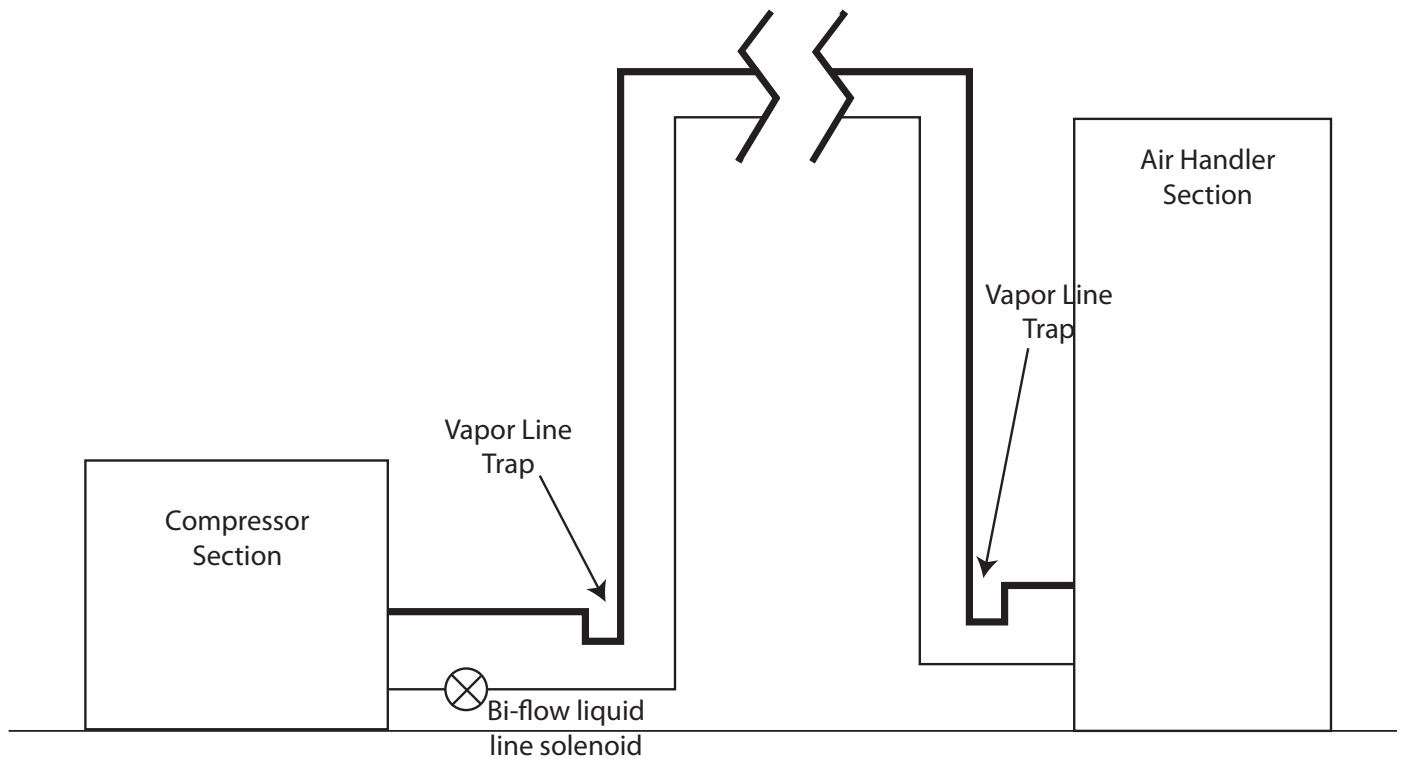

### Notes:

- A Bi-flow liquid line solenoid required if total equivalent length is greater than or equal to 50 feet or the vertical separation is greater than or equal to 20 feet. See tables below for descriptions and part numbers.
- The vapor line must be installed with the horizontal run higher than the top of the evaporator section.
- P-traps should be installed at the outlet of the evaporator section and at the bottom of vapor line drop.
- 75 feet maximum equivalent line length
- 50 feet maximum vertical separation
- Vapor Line sizes on Two-stage units should not be increased due to the velocity requirements for returning oil to the compressor.

Bi-flow Solenoid Data		
Compatible Models	Description	Part Number
All Split Models (24-60)	1/2" Valve Body	ARS-4B
	24V Coil	ARSCB
Only required in long line set applications. All three parts must be ordered.		

## Section 6: Line Set Installation

Figure 15: Horizontal piping above "A" coil

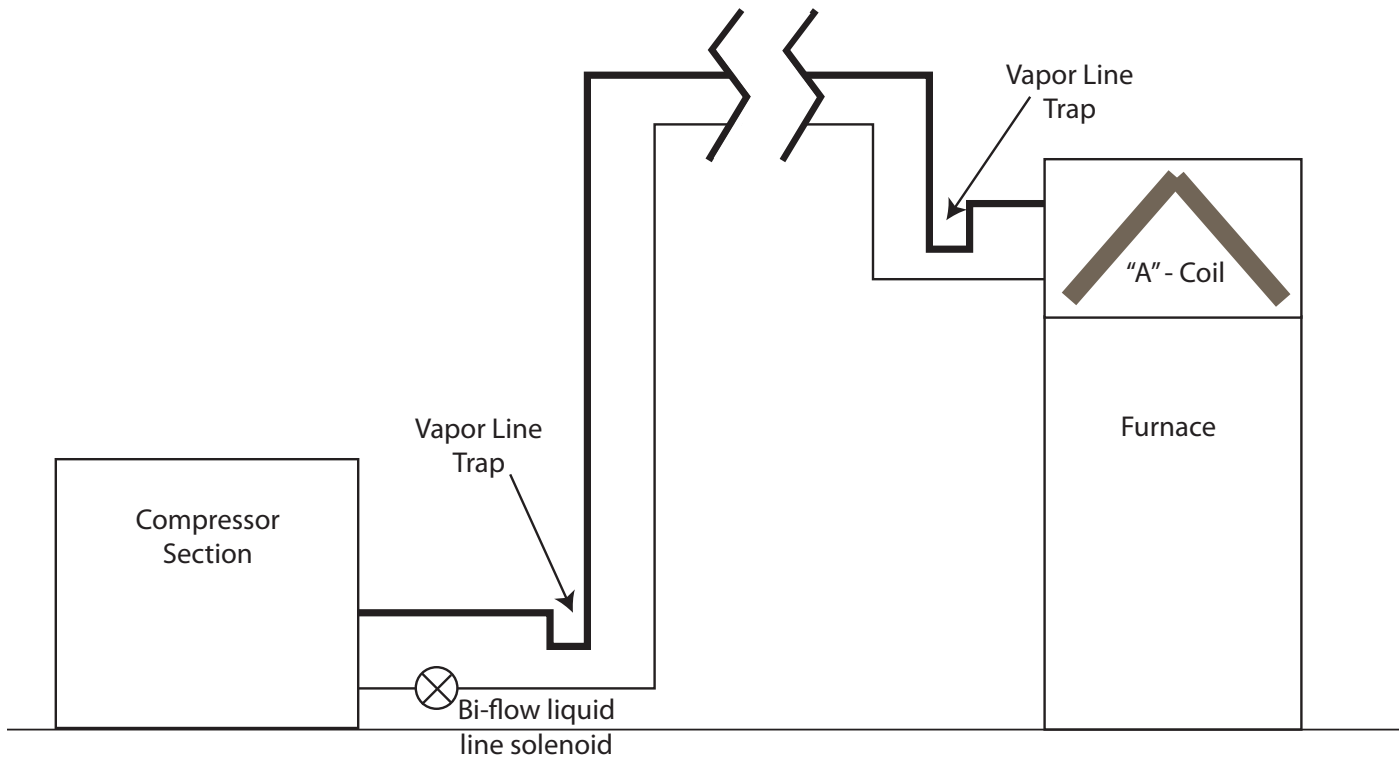

### Notes:

- A Bi-flow liquid line solenoid required if total equivalent length is greater than or equal to 50 feet or the vertical separation is greater than or equal to 20 feet. See tables below for descriptions and part numbers.
- The vapor line must be installed with the horizontal run higher than the top of the evaporator section.
- P-traps should be installed at the outlet of the evaporator section and at the bottom of vapor line drop.
- 75 feet maximum equivalent line length
- 50 feet maximum vertical separation
- Vapor Line sizes on Two-stage units should not be increased due to the velocity requirements for returning oil to the compressor.

Bi-flow Solenoid Data		
Compatible Models	Description	Part Number
All Split Models (24-60)	1/2" Valve Body	ARS-4A
	24V Coil	ARSCB
	Bi-flow kit	ARSBK
Only required in long line set applications. All three parts must be ordered.		

## Section 7: Hot Water Generator Option

### External Hot Water Generator Option Installation:

Enertech's RT Series of Outdoor Split units may be ordered with a Hot Water Generator (HWG) option, (connections only). The factory installed diverting valve and service valve connections allow for easy installation of an external Heat Recovery Unit (HRU). RT units ordered with the HWG option should follow the HRU manufacturer's instructions provided with their the HRU packaging.

#### The following manufacturer's cautions should be observed when installing the HRU:

- The HRU must be placed above the compressor, as close to the outdoor unit as practical.
- It is recommended to utilize 3/4" O.D. insulated copper (5/8" O.D. for 2 ton) and do not exceed 25 ft. one way with the interconnecting refrigerant discharge tubing.
- Place the HRU indoors unless freezing weather conditions are not an issue.
- The water lines should be at least 5/8" O.D., insulated copper, and should not exceed 50 ft. in one direction.
- For potential freezing conditions the HRU must be wired to the line side of the contactor to allow the freeze protection circuit to energize the unit any time during freezing conditions.

#### Unit Connection instructions:

- Remove the top cover as outlined in section 8a
- Braze copper tubes from the external HRU to 1/2" service valves (see Figure 1).
- Evacuate the HRU and the line set to 250micron or less before opening the service valves to the HWG.
- Close 1/2" diverting ball valve and replace the cap (see Figure 2).
- Complete the installation of the HRU in accordance with the manufacturer's instructions.
- With the unit operating, verify the correct operation of the outdoor unit by comparing liquid line temperature to entering water temperature (see section 8c). This section provides data for determining refrigerant charge using the approach method.
- Replace the top cover.

Figure 1.

### HWG Option Component Locations

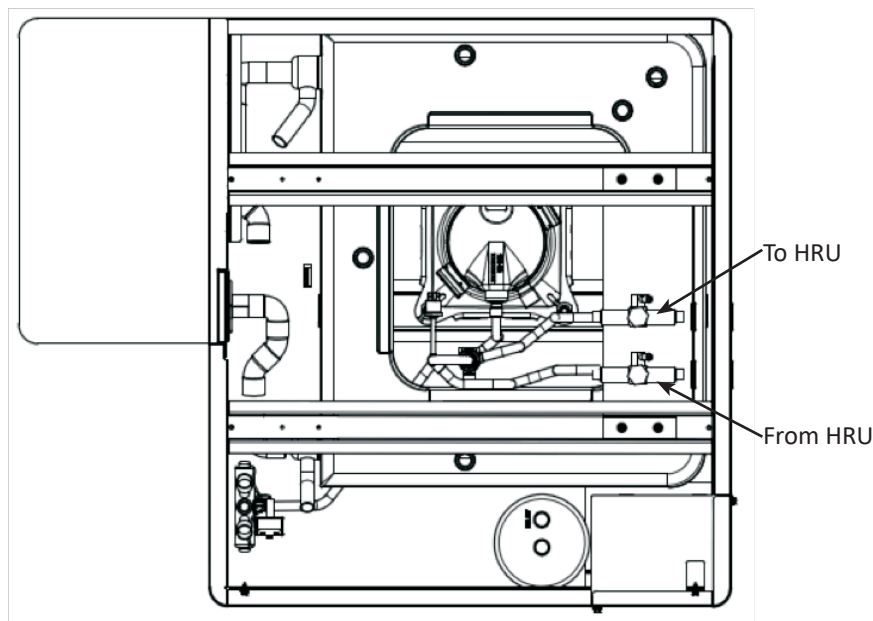



## Section 7: Hot Water Generator Option

### HWG Option Component Locations

Figure 2.

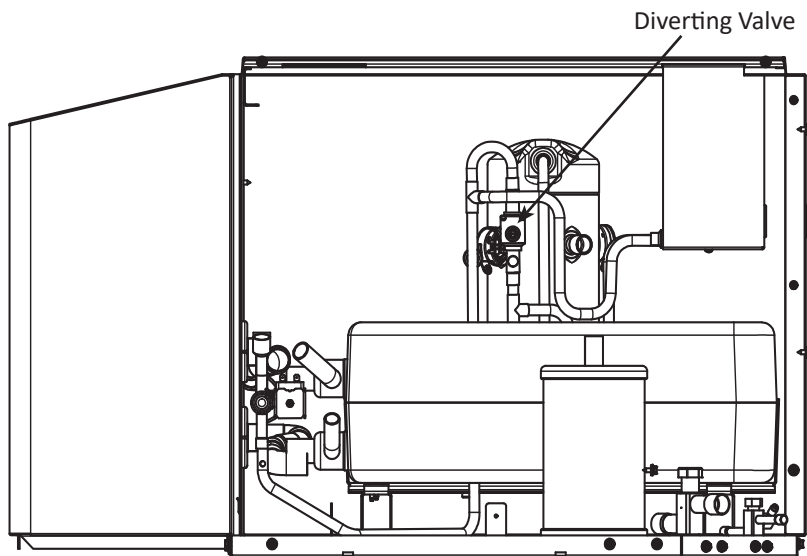
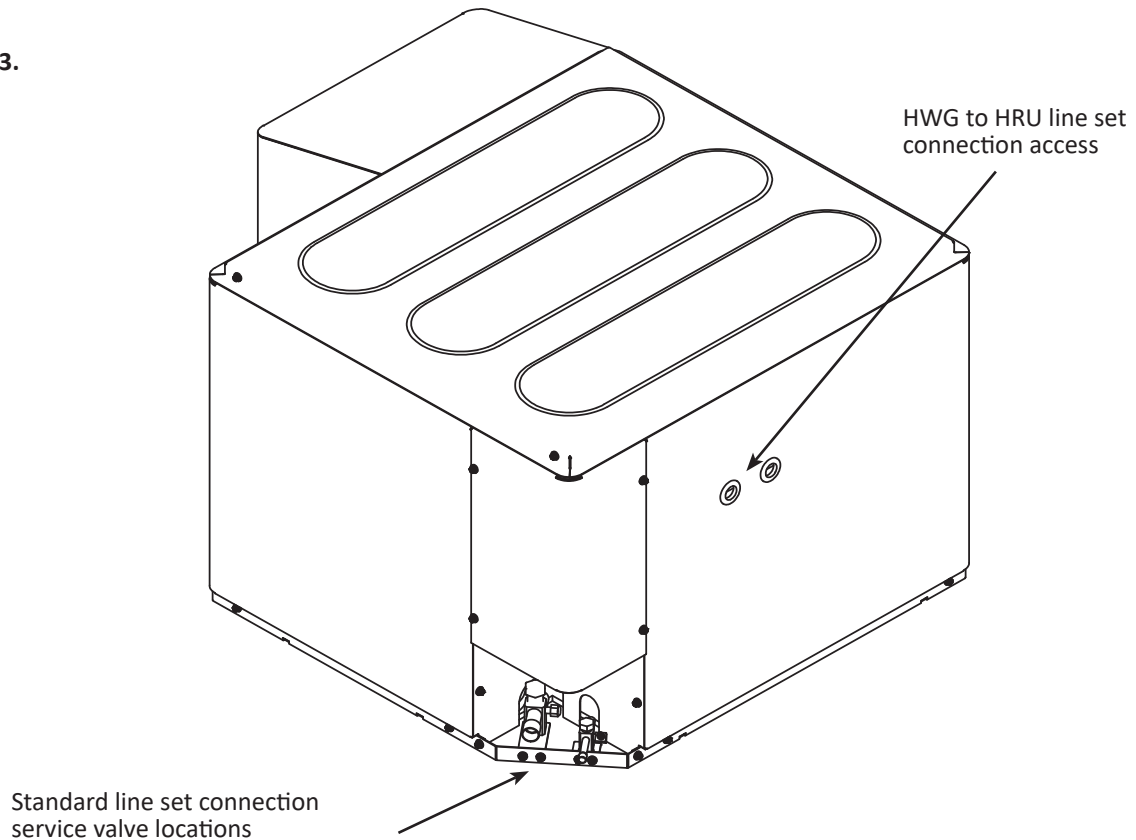

Figure 3.



## Section 8: Unit Piping Installation

### Water Quality

The quality of the water used in geothermal systems is very important. In closed loop systems the dilution water (water mixed with antifreeze) must be of high quality to ensure adequate corrosion protection. Water of poor quality contains ions that make the fluid “hard” and corrosive. Calcium and magnesium hardness ions build up as scale on the walls of the system and reduce heat transfer. These ions may also react with the corrosion inhibitors in glycol based heat transfer fluids, causing them to precipitate out of solution and rendering the inhibitors ineffective in protecting against corrosion. In addition, high concentrations of corrosive ions, such as chloride and sulfate, will eat through any protective layer that the corrosion inhibitors form on the walls of the system.

Ideally, de-ionized water should be used for dilution with antifreeze solutions since de-ionizing removes both corrosive and hardness ions.

Distilled water and zeolite softened water are also acceptable. Softened water, although free of hardness ions, may actually have increased concentrations of corrosive ions and, therefore, its quality must be monitored. It is recommended that dilution water contain less than 100 PPM calcium carbonate or less than 25 PPM calcium plus magnesium ions; and less than 25 PPM chloride or sulfate ions.

In an open loop system the water quality is of no less importance. Due to the inherent variation of the supply water, it should be tested prior to making the decision to use an open loop system. Scaling of the heat exchanger and corrosion of the internal parts are two of the potential problems. The Department of Natural Resources or your local municipality can direct you to the proper testing agency. Please see Table 7 for guidelines.

**Table 7: Water Quality**

Potential Problem	Chemical(s) or Condition	Range for Copper Heat Exchangers	Cupro-Nickel Heat Exchanger Ranges	Stainless Steel Heat Exchanger Ranges
Scaling	Calcium & Magnesium Carbonate	Less than 350 ppm	Less than 350 ppm	Less than 0.1 ppm
Corrosion	pH Range	7 - 9	5 - 9	7 - 9
	Total Dissolved Solids	Less than 1000 ppm	Less than 1500 ppm	No rigid setpoint
	Ammonia, Ammonium Hydroxide	Less than 0.5 ppm	Less than 0.5 ppm	No Limit
	Ammonium Chloride, Ammonium Nitrate	Less than 0.5 ppm	Less than 0.5 ppm	Less than 2-20 ppm
	Calcium/Sodium Chloride <small>See Note 4</small>	Less than 125 ppm	Less than 125 ppm	None Allowed
	Chlorine	Less than 0.5 ppm	Less than 0.5 ppm	Less than 1 ppm*
	Hydrogen Sulfide	None Allowed	None Allowed	Less than 0.05 ppm
Biological Growth	Iron Bacteria	None Allowed	None Allowed	None Allowed
	Iron Oxide	Less than 1 ppm	Less than 1 ppm	Less than 0.2 ppm
Erosion	Suspended Solids - Note 5	Less than 10 ppm	Less than 10 ppm	16-20 mesh strainer recommended
	Water Velocity	Less than 8 ft/s	Less than 12 ft/s	Less than 5.5 m/s in the port

\* Chlorine can not be used with 304 Stainless Steel.

#### Notes

1. Hardness in ppm is equivalent to hardness in mg/l.
2. Grains/gallon = ppm divided by 17.1.
3. Unit internal heat exchangers are not recommended for pool applications or water outside the range of the table. Secondary heat exchangers are required for pool or other applications not meeting the requirements shown above.
4. Saltwater applications (approx. 25,000 ppm) require secondary heat exchangers due to copper piping between the heat exchanger and the unit fittings.
5. Filter for maximum of 600 micron size.

## Section 8: Unit Piping Installation

### Antifreeze Overview

In areas where minimum entering loop temperatures drop below 40°F, or where piping will be routed through areas subject to freezing, antifreeze is required. Alcohols and glycols are commonly used as antifreeze. However, local and state/provincial codes supersede any instructions in this document. The system needs antifreeze to protect the coaxial heat exchanger from freezing and rupturing. Freeze protection should be maintained to 15°F below the lowest expected entering source loop temperature. For example, if 30°F is the minimum expected entering source loop temperature, the leaving source loop temperature could be 22 to 25°F. Freeze protection should be set at 15°F (30-15 = 15°F). To determine antifreeze requirements, calculate how much volume the system holds. Then, calculate how much antifreeze will be needed by determining the percentage of antifreeze required for proper freeze protection. See Tables 9 and 10 for volumes and percentages. The freeze protection should be checked during installation using the proper hydrometer to measure the specific gravity and freeze protection level of the solution.

### Antifreeze Characteristics

Selection of the antifreeze solution for closed loop systems require the consideration of many important factors, which have long-term implications on the performance and life of the equipment. Each area of concern leads to a different “best choice” of antifreeze. *There is no “perfect” antifreeze.* Some of the factors to consider are as follows (Brine = antifreeze solution including water):

**Safety:** The toxicity and flammability of the brine (especially in a pure form).

**Cost:** Prices vary widely.

**Thermal Performance:** The heat transfer and viscosity effect of the brine.

**Corrosiveness:** The brine must be compatible with the system materials.

**Stability:** Will the brine require periodic change out or maintenance?

**Convenience:** Is the antifreeze available and easy to transport and install?

**Codes:** Will the brine meet local and state/provincial codes?

The following are some general observations about the types of brines presently being used:

**Methanol:** Wood grain alcohol that is considered toxic in pure form. It has good heat transfer, low viscosity, is non-corrosive, and is mid to low price. The biggest down side is that it is flammable in concentrations greater than 25%.

**Ethanol:** Grain alcohol, which by the ATF (Alcohol, Tobacco, Firearms) department of the U.S. government, is required to be denatured and rendered unfit to drink. It has good heat transfer, mid to high price, is non-corrosive, non-toxic even in its pure form, and has medium viscosity. It also is flammable with concentrations greater than 25%. Note that the brand of ethanol is very important. Make sure it has been formulated for the geothermal industry. Some of the denaturants are not compatible with HDPE pipe (for example, solutions denatured with gasoline).

**Propylene Glycol:** Non-toxic, non-corrosive, mid to high price, poor heat transfer, high viscosity when cold, and can introduce micro air bubbles when adding to the system. It has also been known to form a “slime-type” coating inside the pipe. Food grade glycol is recommended because some of the other types have certain inhibitors that react poorly with geothermal systems. A 25% brine solution is a minimum required by glycol manufacturers, so that bacteria does not start to form.

**Ethylene Glycol:** Considered toxic and is not recommended for use in earth loop applications.

**GS4 (POTASSIUM ACETATE):** Considered highly corrosive (especially if air is present in the system) and has a very low surface tension, which causes leaks through most mechanical fittings. This brine is not recommended for use in earth loop applications.

### Notes:

1. Consult with your representative or distributor if you have any questions regarding antifreeze selection or use.
2. All antifreeze suppliers and manufacturers recommend the use of either de-ionized or distilled water with their products.

### Antifreeze Charging

Calculate the total amount of pipe in the system and use Table 9 to calculate the amount of volume for each specific section of the system. Add the entire volume together, and multiply that volume by the proper antifreeze percentage needed (Table 9) for the freeze protection required in your area. Then, double check calculations during installation with the proper hydrometer and specific gravity chart (Figure 18) to determine if the correct amount of antifreeze was added.

**Table 8: Pipe Fluid Volume**

Type	Size	Volume Per 100ft US Gallons
Copper	1" CTS	4.1
Copper	1.25" CTS	6.4
Copper	1.5" CTS	9.2
HDPE	.75" SDR11	3.0
HDPE	1" SDR11	4.7
HDPE	1.25" SDR11	7.5
HDPE	1.5" SDR11	9.8
HDPE	2" SDR11	15.4

Additional component volumes:

Unit coaxial heat exchanger = 1 Gallon

Flush Cart = 8-10 Gallons

10' of 1" Rubber Hose = 0.4 Gallons

## Section 8: Unit Piping Installation

**Figure 18: Antifreeze Specific Gravity chart(s)**

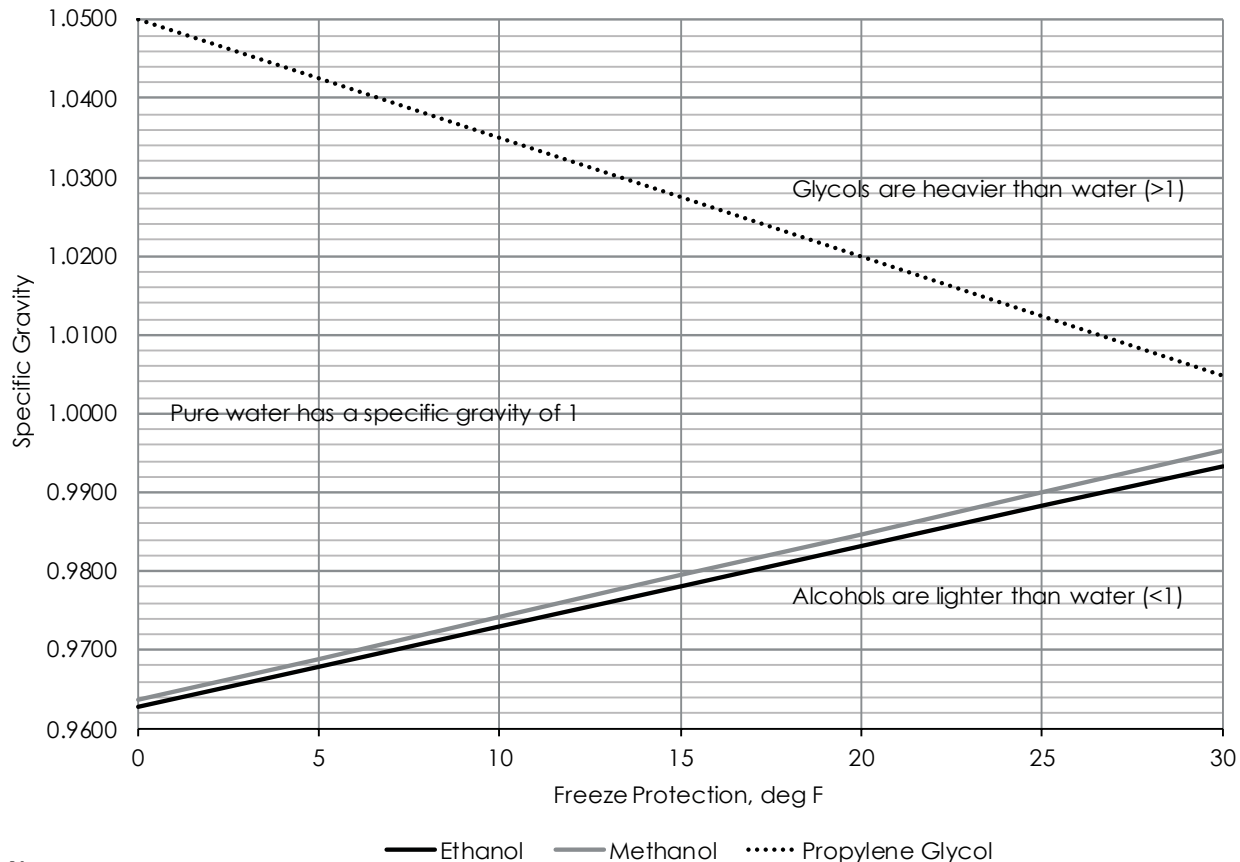

**Notes:**

1. Consult with your representative or distributor if you have any questions regarding antifreeze selection or use.
2. Some antifreeze suppliers and manufacturers recommend the use of either de-ionized or distilled water with their products
3. Some brands are designed to work with tap water. Consult the antifreeze manufacturer's technical data.

**Table 9: Antifreeze Percentages by Volume**

Type of Antifreeze	Minimum Temperature for Freeze Protection			
	10°F (-12.2°C)	15°F (-9.4°C)	20°F (-6.7°C)	25°F (-3.9°C)
ProCool (Ethanol)	26%	23%	18%	13%
Methanol	21%	17%	13%	5%
Propylene Glycol*	30%	25%	20%	13%
Heat Transfer Fluid (HTF)	Mix according to manufacturer's directions on container label			

Antifreeze solutions are shown in pure form - not premixed

HTF is a premixed Methanol solution

\*Concentrations below 25-30% (consult manufacturer) typically require additional inhibitors.

**⚠ CAUTION ⚠**

**USE EXTREME CARE WHEN OPENING, POURING, AND MIXING FLAMMABLE ANTIFREEZE SOLUTIONS. REMOTE FLAMES OR ELECTRICAL SPARKS CAN IGNITE UNDILUTED ANTIFREEZES AND VAPORS. USE ONLY IN A WELL VENTILATED AREA. DO NOT SMOKE WHEN HANDLING FLAMMABLE SOLUTIONS. FAILURE TO OBSERVE SAFETY PRECAUTIONS MAY RESULT IN FIRE, INJURY, OR DEATH. NEVER WORK WITH 100% ALCOHOL SOLUTIONS.**

## Section 9: Controls

### Microprocessor Features and Operation

Enertech Global geothermal heat pump controls provide a unique modular approach for controlling heat pump operation. The control system uses one, two, or three printed circuit boards, depending upon the features of a particular unit. This approach simplifies installation and troubleshooting, and eliminates features that are not applicable for some units. Split units include only the lockout board in the compressor section.

A microprocessor-based printed circuit board controls the inputs to the unit as well as outputs for status mode, faults, and diagnostics. A status LED and an LED for each fault is provided for diagnostics. Removable low voltage terminal strips provide all necessary terminals for field connections.

### Startup/Random Start

The unit will not operate until all the inputs and safety controls are checked for normal conditions. At first power-up, the compressor is energized after a five minute delay. In addition, a zero to sixty second random start delay is added at first power-up to avoid multiple units from being energized at the same time.

### Short Cycle Protection

A built-in five minute anti-short cycle timer provides short cycle protection of the compressor.

### Component Sequencing Delays

Components are sequenced and delayed for optimum space conditioning performance and to make any startup noise less noticeable.

### Test Mode

The microprocessor control allows the technician to shorten most timing delays for faster diagnostics by changing the position of a jumper located on the lockout board.

### Water Solenoid Valve Connections

Two accessory relay outputs at the terminal strip provide a field connection for two types of water solenoid valves, a standard 24VAC solenoid valve, or a 24VAC solenoid valve with an end switch. Additional field wiring is no longer required for operation of the end switch.

### Loop Pump Circuit Breakers (Single Compressor Units)

The loop pump(s) are protected by control box mounted circuit breakers for easy wiring of pumps during installation. Circuit breakers eliminate the need to replace fuses.

### Safety Controls

The control receives separate signals for high pressure, low pressure, low water flow, and condensate overflow faults. Upon a continuous 30-second measurement of the fault (immediate for high pressure), compressor operation is suspended (see Fault Retry below), and the appropriate LED flashes. Once the unit is locked out (see Fault Retry below), an output (terminal "L") is made available to a fault LED at the thermostat (water-to-water unit has fault LED on the corner post).

**Low Pressure:** If the low pressure switch is open for 30 continuous seconds, the compressor operation will be interrupted, and the control will go into fault retry mode. At startup, the low pressure switch is not monitored for 90 seconds to avoid nuisance faults.

**High Pressure:** If the high pressure switch opens, the compressor operation will be interrupted, and the control will go into fault retry mode. There is no delay from the time the switch opens and the board goes into fault retry mode. There is also no delay of switch monitoring at startup.

**Flow Switch:** If the flow switch is open for 30 continuous seconds, the compressor operation will be interrupted, and the control will go into fault retry mode. At startup, the flow switch is not monitored for 30 seconds to avoid nuisance faults.

### Fault Retry

All faults are retried twice before finally locking the unit out. The fault retry feature is designed to prevent nuisance service calls. There is an anti-short cycle period between fault retries. On the third fault, the board will go into lockout mode.

## Section 9: Controls

### Over/Under Voltage Shutdown

The lockout board protects the compressor from operating when an over/under voltage condition exists. The control monitors secondary voltage (24VAC) to determine if an over/under voltage condition is occurring on the primary side of the transformer. For example, if the secondary voltage is 19 VAC, the primary voltage for a 240V unit would be approximately 190V, which is below the minimum voltage (197V) recommended by the compressor manufacturer. This feature is self-resetting. If the voltage comes back within range, normal operation is restored. Therefore, over/under voltage is not a lockout.

Under voltage (18 VAC) causes the compressor to disengage and restart when the voltage returns to 20 VAC. Over voltage (31 VAC) causes the compressor to disengage and restart when the voltage returns to 29 VAC. During an over or under voltage condition, all five fault LEDs will blink (HP + LP + FS + CO + Status). When voltage returns to normal operation, the four fault LEDs will stop blinking, but the status LED will continue to flash. While the board LEDs are flashing, the thermostat fault light will be illuminated.

### Intelligent Reset

If the thermostat is powered off and back on (soft reset), the board will reset, but the last fault will be stored in memory for ease of troubleshooting. If power is interrupted to the board, the fault memory will be cleared.

### Diagnostics

The lockout board includes five LEDs (status, high pressure, low pressure, low water flow, condensate overflow) for fast and simple control board diagnosis. On the following page is a table showing LED function.

**Note:** Condensate overflow is not used for split systems. Any condensate overflow protection must be added to the air handler.

### Lockout Board Jumper Selection

The lockout board includes three jumpers for field selection of various board features.

#### Water Solenoid Valve Delay (WSD)

When the WSD jumper is installed, the "A" terminal is energized when the compressor is energized. When the jumper is removed, the "A" terminal is energized 10 seconds after the compressor. If using the Taco water solenoid valve (or a valve with an end switch), the unit terminal strip includes a means for connecting a valve of this type. The WSD jumper should be installed. If using a fast opening valve that does not have an end switch, the jumper should be removed.

#### Test Mode (TEST)

When the TEST jumper is installed, the board operates in the normal mode. When the jumper is removed, the board operates in test mode, which speeds up all delays for easier troubleshooting. When service is complete, the jumper must be re-installed in order to make sure that the unit operates with normal sequencing delays.

#### Over/Under Voltage Disable (O/V)

When the O/V jumper is installed, the over/under voltage feature is active. When the jumper is removed, the over/under voltage feature is disabled. On rare occasions, variations in voltage will be outside the range of the over/under voltage feature, which may require removal of the jumper. However, removal of the jumper could cause the unit to run under adverse conditions, and therefore should not be removed without contacting technical services. An over/under voltage condition could cause premature component failure or damage to the unit controls. Any condition that would cause this fault must be thoroughly investigated before taking any action regarding the jumper removal. Likely causes of an over/under voltage condition include power company transformer selection, insufficient entrance wire sizing, defective breaker panel, incorrect transformer tap (unit control box), or other power-related issues.

**Table 10: LED Identification**

LED Color	Location <sup>1</sup>	Function	Normal Operation	Fault Retry <sup>2</sup>	Lockout <sup>2</sup>
Green	Top	High Pressure	OFF	Flashing <sup>3</sup>	ON <sup>3</sup>
Orange	2nd	Low Pressure	OFF	Flashing <sup>3</sup>	ON <sup>3</sup>
Red	3rd	Water Flow	OFF	Flashing <sup>3</sup>	ON <sup>3</sup>
Yellow	4th	Condensate* Overflow	OFF	Flashing <sup>3</sup>	ON <sup>3</sup>
Green	Bottom	Status	Flashing <sup>4</sup>	Flashing <sup>5</sup>	Flashing <sup>4</sup>

#### Notes:

- Looking at the board when the LEDs are on the right hand side
- If all five lights are flashing, the fault is over/under voltage
- Only the light associated with the particular fault/lockout will be on or flashing.  
For example, if a high pressure lockout has occurred, the top green light will be on.  
The orange, red, and yellow lights will be off
- Status lights will be off when in test mode
- Flashes alternately with the fault LED  
\* Not applicable in split units



## Section 9: Controls

### Sequence of Operation

Water-to-Air Units, Single Compressor, ECM Fan

#### Heating, 1st Stage (Y1,G)

The ECM fan is started immediately at 75% (of 1st stage operation) CFM level, first stage compressor and the loop pump(s) are energized 10 seconds after the “Y1” input is received, and the ECM fan adjusts to 100% (of 1st stage operation) CFM level 30 seconds after the “Y1” input.

#### Heating, 2nd Stage (Y1,Y2,G)

The ECM fan adjusts to 2nd stage CFM level, and the compressor full load solenoid valve is energized.

#### Heat, 3rd Stage (Y1,Y2,W,G)

The ECM fan remains at 100% of 2nd stage CFM level, and the electric backup heat is energized.

#### Emergency Heat (W,G)

The fan is started immediately at 100% of 2nd stage CFM level, and the electric backup heat is energized.

#### Cooling Operation

The reversing valve is energized for cooling operation. Terminal “O” from the thermostat is connected to the reversing valve solenoid.

#### Cooling, 1st stage (Y1,O,G) Two-Stage Units

The ECM fan is started immediately at 75% (of 1st stage operation) CFM level, first stage compressor and the loop pump(s) are energized 10 seconds after the “Y1” input is received, and the ECM fan adjusts to 100% (of 1st stage operation) CFM level 30 seconds after the “Y1” input.

#### Cooling, 2nd Stage (Y1,Y2,O,G)

The ECM fan adjusts to 2nd stage CFM level, and the compressor full load solenoid valve is energized.

#### Fan Only

When the ECM control module receives a “G” call without a call for heating or cooling, the fan operates at 50% of the full load CFM level.

#### Thermostat Wiring / Fan Speed Notes

For two-stage compressor section units, wire as shown in the wiring diagram on the following page. The ECM control board in the air handler is the thermostat connection point. Wire nut the thermostat wiring to the “pigtailed” connected to the 1/4” spades on the ECM board.

For dehumidification in cooling, cut the resistor at the “DEHUMIDIFY” LED. Use either the HUM terminal (reverse logic -- designed to be used with a humidistat) to lower the fan speed when dehumidification is needed, or if the HUM terminal is not connected (and the resistor is cut), the air handler will operate at a lower fan speed in cooling and normal fan speed in heating.

Figure 19: Lockout Board (Compr Section)

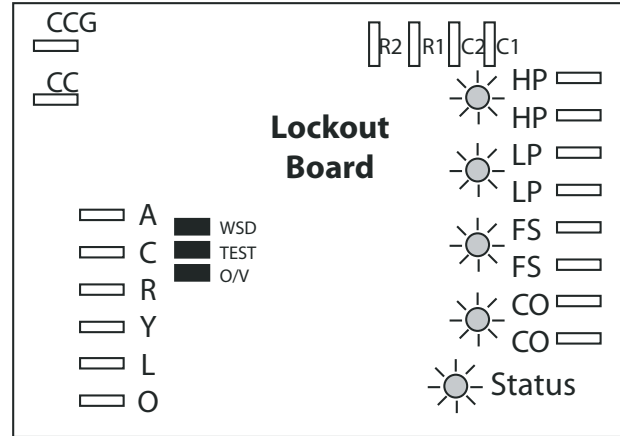

#### Accessories

##### APSMA Pump Sharing Module

The pump sharing module, part number APSMA, is designed to allow two units to share one flow center. With the APSMA module, either unit can energize the pump(s). Connect the units and flow center as shown in Figure 21, below. Figure 22 includes a schematic of the board. The module must be mounted in a NEMA enclosure or inside the unit control box. Local code supersedes any recommendations in this document.

Figure 21: APSMA Module Layout

Board Layout

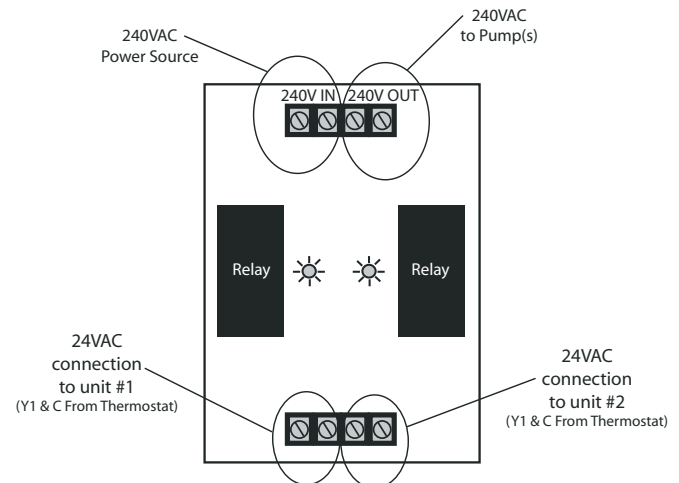
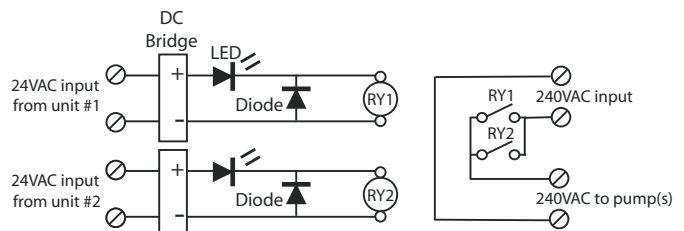

Figure 22: APSMA Module Wiring Schematic



# Section 10: Wiring Diagram

## Unit Wiring Diagram

### WATER-TO-AIR SPLIT SYSTEM, TWO-STAGE COMPRESSOR, SINGLE PHASE, 60 HZ

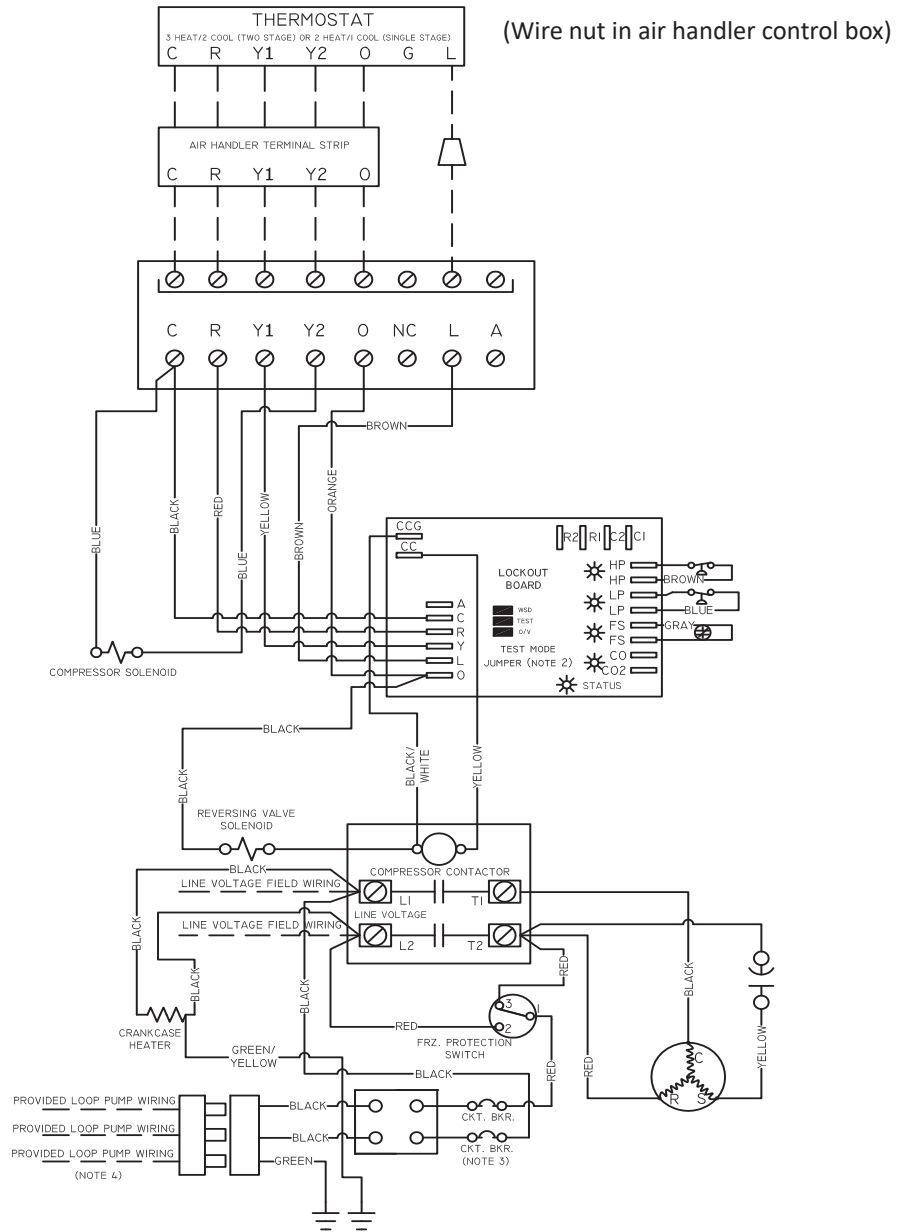

**NOTES:**

1. FACTORY INSTALLED JUMPER. REMOVE FOR USE WITH SOLENOID VALVE WITH END SWITCH. VERIFY THAT AIR HANDLER TRANSFORMER IS AT LEAST 50VA FOR UNITS WITHOUT WATER SOLENOID VALVE(S), OR 75VA FOR UNITS WITH WATER SOLENOID VALVE(S).
2. JUMPER INSTALLED-NORMAL; JUMPER REMOVED-TEST.
3. CIRCUIT BREAKERS ARE INSTALLED ON RESIDENTIAL MODELS ONLY.
4. LOOP PUMP WIRING HARNESS IS PROVIDED IN LOOP PUMP KIT.

## Section 11: Equipment Start-up

### Equipment Start-Up Form

Customer Name: \_\_\_\_\_

Customer Address: \_\_\_\_\_

Model #: \_\_\_\_\_ Serial #: \_\_\_\_\_

Dealer Name: \_\_\_\_\_

Distributor Name: \_\_\_\_\_ Start-up Date: \_\_\_\_\_

Loop Type: Open Closed (Circle One)								
Flow Rate	Cooling		Heating		Unit Electrical Data	Cooling	Heating	
Source Water Pressure In		PSI		PSI	Line Voltage		V	
Source Water Pressure Out		PSI		PSI	Total Unit Amps		A	A
Source Water Pressure Drop		PSI		PSI	Compressor Amps		A	A
Flow Rate		GPM		GPM	Wire Size		GA	
*Check pressure drop chart for GPM					Circuit Breaker Size		A	

Source Water Temp. Difference	Cooling		Heating	
Source Water Temperature In		°F		°F
Source Water Temperature Out		°F		°F
Source Water Temperature Difference		°F		°F
Heat of Rejection/Extraction	Cooling		Heating	
Heat of Rejection		BTU/HR		
Heat Of Extraction				BTU/HR

Heat of Extraction/Rejection = GPM X Water Temp. Difference X 500 (Water - Open Loop)

Heat of Extraction/Rejection = GPM X Water Temp. Difference X 485 (Water & Antifreeze - Closed Loop)

Load Water Temp. Difference	Cooling		Heating	
Load Water Temperature In		°F		°F
Load Water Temperature Out		°F		°F
Load Water Temperature Difference		°F		°F
Air Temperature Difference	Cooling		Heating	
Supply Air Temperature		°F		°F
Return Air Temperature		°F		°F
Air Temp. Difference		°F		°F
*Confirm auxiliary heaters are de-energized for the above readings.				
<b>Auxiliary Heat Operation Only</b>				<b>Heating</b>
Supply Air Temperature				°F
Return Air Temperature				°F
Air Temp. Difference				°F
<b>Auxiliary Heat Electrical Data</b>				<b>Heating</b>
Line Voltage				V
Total Amperage (Full kW - All Stages)				A
Wire Size				GA
Breaker Size				A
CFM = (Watts X 3.413) ÷ (Air Temp. Difference X 1.08)				
Watts = Volts X Auxiliary Heater Amps				

Installer/Technician: \_\_\_\_\_ Date: \_\_\_\_\_

## Section 11: Equipment Start-up

### Equipment Start-Up Process Form

#### Check the following before power is applied to the equipment

Caution: Do not start-up the unit until the new structure is ready to be occupied

##### Electrical:

- Geothermal unit high voltage wiring is installed correctly
- Geothermal unit high voltage wiring and breaker are the correct size
- Auxiliary electric heaters are wired and installed correctly
- Circulating pumps are wired and fused (if necessary) correctly
- Desuperheater pump is NOT wired, unless piping is complete and all air is purged
- Low voltage wiring is correct and completely installed

##### Plumbing:

- Pipe and pump sizes are correct
- Air is purged from all lines
- Antifreeze is installed
- All valves are open, including those on the flow center
- Condensate is trapped and piped to the drain

##### Ductwork:

- Filter is installed and clean
- Packaging is removed from the blower assembly
- Blower turns freely
- Canvas connections installed on supply plenum & return drop

#### Equipment Start-Up

1. Energize geothermal unit with high voltage.
2. Set the thermostat to "Heat" or "Cool." Adjust set point to energize the unit. System will energize after delays expire (typically a five minute delay).
3. Check water flow with a flow meter (non-pressurized) or pressure drop conversion (pressurized). Pressure drop tables must be used to convert the pressure drop to GPM. The pressure drop can be obtained by checking water pressure in and water pressure out at the P/T ports.
4. Check the geothermal unit's electrical readings listed in the Unit Electrical Data table.
5. Check the source water temperature in and out at the P/T ports (use insertion probe). Allow 10 minutes of operation before recording temperature drop.
6. Calculate the heat of extraction or heat of rejection.
7. Check the temperature difference of the load coax (water-to-water) or air coil (water-to-air). P/T ports are recommended for use on the load side, but the line temperatures can be used to check the temperature difference.
8. Change the mode of the thermostat and adjust the set point to energize the unit. Check the data in opposite mode as the previous tests. Amp draws as well as temperature differences and flow rate should be recorded.
9. Check auxiliary heat operation by adjusting the thermostat set point 5°F above the room temperature in "Heat" mode or set thermostat to "Emergency." Record voltage, amperage, and air temperature difference.

## Section 12: Troubleshooting

### Model 024 Pressure Drop Table

Model	Source GPM	Source Brine Pressure Drop at Various Entering Source Temperatures (°F)									
		25		30		50		70		90	
		PSI	FT HD	PSI	FT HD	PSI	FT HD	PSI	FT HD	PSI	FT HD
RT024 Part Load Heating	3	2.0	4.6	1.6	3.7	1.3	2.9	1.0	2.4	1.0	2.2
	4	2.3	5.3	1.8	4.2	1.5	3.4	1.2	2.7	1.1	2.6
	5	4.0	9.2	3.2	7.3	2.5	5.8	2.1	4.8	2.0	4.5
	6	5.3	12.3	4.3	9.8	3.4	7.8	2.8	6.4	2.6	6.0
RT024 Full Load Heating	3	0.9	2.0	0.8	1.8	0.7	1.6	0.6	1.4	0.5	1.2
	4	1.9	4.4	1.7	4.0	1.5	3.5	1.3	3.1	1.2	2.7
	5	3.0	7.0	2.7	6.3	2.4	5.6	2.1	4.8	1.8	4.3
	6	4.2	9.8	3.9	8.9	3.4	7.8	3.0	6.8	2.6	6.0
RT024 Part Load Cooling	3	0.5	1.0	0.6	1.3	0.7	1.6	0.6	1.3	0.5	1.2
	4	0.9	2.1	1.2	2.7	1.4	3.2	1.2	2.7	1.0	2.4
	5	1.4	3.2	1.8	4.1	2.1	4.8	1.8	4.1	1.6	3.7
	6	2.1	4.7	2.6	6.1	3.1	7.1	2.6	6.0	2.3	5.3
RT024 Full Load Cooling	3	0.6	1.4	0.6	1.3	0.5	1.1	0.4	1.0	0.4	0.8
	4	1.9	4.4	1.8	4.3	1.5	3.5	1.4	3.1	1.2	2.8
	5	3.1	7.1	2.9	6.8	2.4	5.6	2.2	5.0	1.9	4.4
	6	4.1	9.4	3.9	9.0	3.2	7.4	2.8	6.6	2.5	5.9

1. Source WPD data are based on 15% (by mass) methanol solution while the unit is operating.
2. Pressure drop data accurate within ±25%.
3. Unit test is run without hot water generation.
4. Interpolation of unit pressure drop data is permissible; extrapolation is not.
5. Pressure drop data is a result of lab testing and is not related to warranty.
6. Due to variations in installation, actual unit performance may vary from the tabulated data.

### Model 024 Heat of Extraction/Rejection Table

MODEL		GPM	CFM		Heat of Extraction (MBtuh) at Source T (°F)				Heat of Rejection (MBtuh) at Source T (°F)			
			Heating	Cooling	30	50	70	90	50	70	90	110
RT024 / AD024	PART LOAD	3	710	737	9.3	13.6	17.8	20.9	26.3	25.0	23.7	21.6
		4	710	737	9.6	14.2	18.5	21.7	26.3	25.0	23.7	21.6
		5	710	737	9.8	14.4	18.8	22.1	26.4	25.1	23.8	21.7
		6	710	737	9.9	14.6	19.0	22.3	26.7	25.3	24.0	21.9
	FULL LOAD	3	838	875	13.6	18.1	23.2	26.5	32.9	33.0	31.8	30.3
		4	838	875	14.3	18.9	24.2	27.7	32.8	32.9	31.7	30.2
		5	838	875	14.5	19.2	24.7	28.2	32.8	32.9	31.6	30.2
		6	838	875	14.7	19.5	24.9	28.6	33.0	33.1	31.8	30.4

1. Capacity data is based on 15% (by mass) methanol antifreeze solution (multiplier: 485).
2. Heating data is based on 70°F EAT. Cooling data is based on 80/67°F EAT. Any condition outside performance table(s) requires correction factor(s).
3. Performance data accurate within ±15%.
4. Unit performance test is run without hot water generation.
5. Capacity data includes fan power but not pump power and it does not reflect fan or pump power correction for AHRI/ISO conditions.
6. Performance data is based upon the lower voltage of dual voltage rated units.
7. Interpolation of unit performance data is permissible; extrapolation is not.
8. Performance data is a result of lab testing and is not related to warranty.
9. Due to variations in installation, actual unit performance may vary from the tabulated data.

## Section 12: Troubleshooting

### Model 036 Pressure Drop Table

Model	Source GPM	Source Brine Pressure Drop at Various Entering Source Temperatures (°F)									
		25		30		50		70		90	
		PSI	FT HD	PSI	FT HD	PSI	FT HD	PSI	FT HD	PSI	FT HD
RT036 Part Load Heating	3	0.5	1.2	0.5	1.2	0.4	1.0	0.4	0.8	0.3	0.7
	4.5	1.1	2.6	1.1	2.5	0.9	2.2	0.8	1.8	0.7	1.6
	6.75	2.5	5.7	2.4	5.5	2.0	4.7	1.7	4.0	1.5	3.5
	9	4.1	9.4	3.9	9.0	3.3	7.7	2.8	6.5	2.5	5.8
RT036 Full Load Heating	3	0.6	1.3	0.6	1.3	0.5	1.1	0.4	0.9	0.4	0.9
	4.5	1.2	2.7	1.1	2.6	1.0	2.2	0.8	1.9	0.7	1.7
	6.75	2.6	5.9	2.5	5.7	2.1	4.8	1.8	4.2	1.6	3.8
	9	4.1	9.5	4.0	9.1	3.3	7.7	2.9	6.7	2.6	6.0
RT036 Part Load Cooling	3	0.6	1.4	0.6	1.4	0.5	1.3	0.5	1.1	0.4	1.0
	4.5	1.1	2.6	1.1	2.6	1.0	2.3	0.9	2.0	0.8	1.8
	6.75	2.2	5.0	2.1	5.0	1.9	4.4	1.7	3.9	1.5	3.4
	9	3.5	8.2	3.5	8.1	3.1	7.3	2.8	6.3	2.4	5.6
RT036 Full Load Cooling	3.75	1.0	2.2	0.9	2.1	0.8	1.8	0.7	1.6	0.6	1.5
	4.5	1.2	2.8	1.2	2.7	1.0	2.3	0.9	2.0	0.8	1.8
	6.75	2.4	5.5	2.3	5.3	2.0	4.6	1.7	4.0	1.6	3.6
	9	3.8	8.8	3.7	8.5	3.2	7.3	2.8	6.4	2.5	5.8

1. Source WPD data are based on 15% (by mass) methanol solution while the unit is operating.
2. Pressure drop data accurate within ±25%.
3. Unit test is run without hot water generation.
4. Interpolation of unit pressure drop data is permissible; extrapolation is not.
5. Pressure drop data is a result of lab testing and is not related to warranty.
6. Due to variations in installation, actual unit performance may vary from the tabulated data.

### Model 036 Heat of Extraction/Rejection Table

MODEL	GPM	CFM		Heat of Extraction (MBtuh) at Source T (°F)				Heat of Rejection (MBtuh) at Source T (°F)				
		Heating	Cooling	30	50	70	90	50	70	90	110	
RT036 / AD036	PART LOAD	3	1144	1034	13.9	19.9	25.8	32.1	36.8	34.7	33.9	31.6
		4.5	1144	1034	14.6	21.0	27.2	33.9	36.6	34.4	33.7	31.4
		6.75	1144	1034	15.3	21.9	28.4	35.4	37.1	34.9	34.2	31.8
		9	1144	1034	15.5	22.2	28.7	35.8	37.3	35.1	34.3	32.0
	FULL LOAD	3	1435	1283	18.9	25.7	33.3	40.4	46.9	45.6	43.1	42.1
		4.5	1435	1283	21.2	28.8	37.3	45.3	48.1	46.7	44.2	43.2
		6.75	1435	1283	21.0	28.6	37.0	44.9	47.7	46.4	43.9	42.9
		9	1435	1283	22.4	30.6	39.5	48.0	48.2	46.8	44.3	43.3

1. Capacity data is based on 15% (by mass) methanol antifreeze solution (multiplier: 485).
2. Heating data is based on 70°F EAT. Cooling data is based on 80/67°F EAT. Any condition outside performance table(s) requires correction factor(s).
3. Performance data accurate within ±15%.
4. Unit performance test is run without hot water generation.
5. Capacity data includes fan power but not pump power and it does not reflect fan or pump power correction for AHRI/ISO conditions.
6. Performance data is based upon the lower voltage of dual voltage rated units.
7. Interpolation of unit performance data is permissible; extrapolation is not.
8. Performance data is a result of lab testing and is not related to warranty.
9. Due to variations in installation, actual unit performance may vary from the tabulated data.



## Section 12: Troubleshooting

### Model 048 Pressure Drop Table

Model	Source GPM	Source Brine Pressure Drop at Various Entering Source Temperatures (°F)									
		25		30		50		70		90	
		PSI	FT HD	PSI	FT HD	PSI	FT HD	PSI	FT HD	PSI	FT HD
RT048 Part Load Heating	4	1.4	3.3	1.4	3.2	1.2	2.7	1.0	2.3	0.9	2.0
	6	2.0	4.6	1.9	4.4	1.6	3.7	1.4	3.2	1.2	2.7
	9	3.9	9.0	3.8	8.7	3.2	7.4	2.7	6.2	2.3	5.4
	12	6.2	14.2	6.0	13.7	5.0	11.6	4.3	9.8	3.7	8.6
RT048 Full Load Heating	4	1.0	2.3	0.9	2.2	0.8	1.8	0.7	1.6	0.6	1.4
	6	2.0	4.7	1.9	4.5	1.6	3.8	1.4	3.3	1.3	2.9
	9	4.0	9.3	3.9	8.9	3.2	7.4	2.8	6.5	2.5	5.8
	12	6.4	14.7	6.1	14.0	5.1	11.7	4.4	10.3	4.0	9.1
RT048 Part Load Cooling	4	1.4	3.3	1.4	3.2	1.1	2.6	1.0	2.3	0.9	2.0
	6	2.0	4.5	1.9	4.3	1.6	3.6	1.3	3.1	1.2	2.7
	9	3.8	8.8	3.6	8.4	3.0	7.0	2.6	6.1	2.3	5.3
	12	6.1	14.2	5.9	13.5	4.9	11.2	4.2	9.7	3.7	8.4
RT048 Full Load Cooling	5	1.4	3.2	1.3	3.1	1.1	2.6	1.0	2.3	0.9	2.0
	6	1.8	4.3	1.8	4.1	1.5	3.5	1.3	3.1	1.2	2.7
	9	3.6	8.2	3.5	8.0	2.9	6.8	2.6	5.9	2.3	5.3
	12	5.8	13.4	5.6	13.0	4.8	11.0	4.2	9.6	3.7	8.6

1. Source WPD data are based on 15% (by mass) methanol solution while the unit is operating.
2. Pressure drop data accurate within ±25%.
3. Unit test is run without hot water generation.
4. Interpolation of unit pressure drop data is permissible; extrapolation is not.
5. Pressure drop data is a result of lab testing and is not related to warranty.
6. Due to variations in installation, actual unit performance may vary from the tabulated data.

### Model 048 Heat of Extraction/Rejection Table

MODEL		GPM	CFM		Heat of Extraction (MBtuh) at Source T (°F)				Heat of Rejection (MBtuh) at Source T (°F)			
			Heating	Cooling	30	50	70	90	50	70	90	110
RT048 / AD048	PART LOAD	4	1424	1278	14.8	22.3	28.0	34.1	37.0	36.9	34.7	33.4
		6	1424	1278	18.8	28.4	35.7	43.5	46.1	45.9	43.1	41.5
		9	1424	1278	20.0	30.2	37.9	46.3	47.5	47.3	44.4	42.8
		12	1424	1278	19.3	29.1	36.5	44.5	45.8	45.7	42.9	41.2
	FULL LOAD	4	1873	1626	27.5	36.0	48.1	56.1	65.9	62.6	61.3	57.5
		6	1873	1626	28.6	37.5	50.1	58.3	66.0	62.8	61.5	57.7
		9	1873	1626	30.1	39.4	52.7	61.3	66.3	63.1	61.8	58.0
		12	1873	1626	29.5	38.6	51.6	60.1	66.2	62.9	61.6	57.8

1. Capacity data is based on 15% (by mass) methanol antifreeze solution (multiplier: 485).
2. Heating data is based on 70°F EAT. Cooling data is based on 80/67°F EAT. Any condition outside performance table(s) requires correction factor(s).
3. Performance data accurate within ±15%.
4. Unit performance test is run without hot water generation.
5. Capacity data includes fan power but not pump power and it does not reflect fan or pump power correction for AHRI/ISO conditions.
6. Performance data is based upon the lower voltage of dual voltage rated units.
7. Interpolation of unit performance data is permissible; extrapolation is not.
8. Performance data is a result of lab testing and is not related to warranty.
9. Due to variations in installation, actual unit performance may vary from the tabulated data.

## Section 12: Troubleshooting

### Model 060 Pressure Drop Table

Model	Source GPM	Source Brine Pressure Drop at Various Entering Source Temperatures (°F)									
		25		30		50		70		90	
		PSI	FT HD	PSI	FT HD	PSI	FT HD	PSI	FT HD	PSI	FT HD
RT060 Part Load Heating	5	1.8	4.1	1.7	3.9	1.4	3.3	1.2	2.8	1.1	2.5
	7.5	3.6	8.3	3.4	8.0	2.9	6.7	2.5	5.8	2.2	5.1
	11.25	7.0	16.1	6.7	15.5	5.6	13.0	4.9	11.2	4.3	10.0
	15	11.0	25.4	10.6	24.4	8.9	20.4	7.7	17.7	6.8	15.8
RT060 Full Load Heating	5	1.8	4.1	1.7	3.9	1.4	3.3	1.3	2.9	1.2	2.7
	7.5	3.6	8.4	3.5	8.0	2.9	6.7	2.6	5.9	2.3	5.4
	11.25	7.1	16.5	6.8	15.7	5.7	13.2	5.1	11.7	4.6	10.6
	15	11.2	25.9	10.7	24.7	9.0	20.8	7.9	18.3	7.2	16.7
RT060 Part Load Cooling	5	1.7	3.9	1.6	3.7	1.3	3.1	1.2	2.7	1.1	2.5
	7.5	3.3	7.6	3.2	7.3	2.7	6.1	2.3	5.4	2.1	4.9
	11.25	6.5	15.0	6.3	14.4	5.3	12.1	4.6	10.7	4.2	9.7
	15	10.5	24.2	10.1	23.3	8.5	19.6	7.5	17.2	6.8	15.7
RT060 Full Load Cooling	5	1.6	3.7	1.5	3.5	1.3	2.9	1.1	2.6	1.0	2.4
	7.5	3.3	7.6	3.1	7.3	2.6	6.1	2.3	5.4	2.1	5.0
	11.25	6.5	15.0	6.2	14.4	5.2	12.0	4.6	10.7	4.3	9.8
	15	10.6	24.3	10.1	23.3	8.5	19.6	7.5	17.4	6.9	15.9

1. Source WPD data are based on 15% (by mass) methanol solution while the unit is operating.
2. Pressure drop data accurate within ±25%.
3. Unit test is run without hot water generation.
4. Interpolation of unit pressure drop data is permissible; extrapolation is not.
5. Pressure drop data is a result of lab testing and is not related to warranty.
6. Due to variations in installation, actual unit performance may vary from the tabulated data.

### Model 060 Heat of Extraction/Rejection Table

MODEL	GPM	CFM		Heat of Extraction (MBtuh) at Source T (°F)				Heat of Rejection (MBtuh) at Source T (°F)				
		Heating	Cooling	30	50	70	90	50	70	90	110	
RT060 / AD060	PART LOAD	5	1465	1544	21.9	31.3	40.7	50.3	58.6	56.3	52.7	49.0
		7.5	1465	1544	23.4	33.4	43.5	53.7	58.8	56.5	52.9	49.2
		11.25	1465	1544	24.0	34.3	44.6	55.0	59.1	56.8	53.1	49.4
		15	1465	1544	25.1	35.9	46.7	57.6	59.2	56.8	53.2	49.5
	FULL LOAD	5	1728	1840	31.1	42.1	53.9	62.9	71.9	74.1	70.2	67.3
		7.5	1728	1840	33.2	44.9	57.4	67.1	73.6	75.8	71.8	68.8
		11.25	1728	1840	34.3	46.4	59.3	69.3	73.0	75.2	71.3	68.3
		15	1728	1840	34.6	46.8	59.9	70.0	73.6	75.8	71.9	68.9

1. Capacity data is based on 15% (by mass) methanol antifreeze solution (multiplier: 485).
2. Heating data is based on 70°F EAT. Cooling data is based on 80/67°F EAT. Any condition outside performance table(s) requires correction factor(s).
3. Performance data accurate within ±15%.
4. Unit performance test is run without hot water generation.
5. Capacity data includes fan power but not pump power and it does not reflect fan or pump power correction for AHRI/ISO conditions.
6. Performance data is based upon the lower voltage of dual voltage rated units.
7. Interpolation of unit performance data is permissible; extrapolation is not.
8. Performance data is a result of lab testing and is not related to warranty.
9. Due to variations in installation, actual unit performance may vary from the tabulated data.

## Section 12: Troubleshooting

### Performance Check

Heat of Extraction(HE)/Rejection(HR)

Record information on the Unit Start-up Form

Equipment should be in full load operation for a minimum of 10 minutes in either mode – **WITH THE HOT WATER GENERATOR TURNED OFF.**

1. Determine flow rate in gallons per minute
  - a. Check entering water temperature
  - b. Check entering water pressure
  - c. Check leaving water pressure

Once this information is recorded, find corresponding entering water temperature column in Specification Manual for unit. Find pressure differential in PSI column in Spec Manual. Then read the GPM column in Spec Manual to determine flow in GPM.

2. Check leaving water temperature of unit.  
 FORMULA: GPM x water temp diff, x 485 (antifreeze) or 500 (fresh water) = HE or HR in BTU/HR

A 10% variance from Spec Manual is allowed. Always use the same pressure gauge & temperature measuring device. Water flow must be in range of Specification Manual. If system has too much water flow, performance problems should be expected

#### A: Unit will not start in either cycle

Thermostat	Set thermostat on heating and highest temperature setting. Unit should run. Set thermostat on cooling and lowest temperature setting. Unit should run. Set fan to On position. Fan should run. If unit does not run in any position, disconnect wires at heat pump terminal block and jump R, G, Y. Unit should run in heating. If unit runs, replace thermostat with correct thermostat only.
Loose or broken wires	Tighten or replace wires.
Blown Fuse/ Tripped Circuit Breakers	Check fuse size, replace fuse or reset circuit breaker. Check low voltage circuit breaker.
Low Voltage Circuit	Check 24 volt transformer. If burned out or less than 24 volt, replace. Before replacing, verify tap setting and correct if necessary.
Water Flow	If water flow is low (less than 3.5 GPM), unit will not start. Make sure Pump Module or solenoid valve is connected (see wiring diagram). Water has to flow through the heat exchanger in the right direction (see labels at water fitting connections) before the compressor can start. If water flow is at normal flow, use an ohmmeter to check if you get continuity at the flow switch. If no switch is open and flow is a normal flow, remove switch and check for stuck particles or bad switch.

#### B: Unit Running Normal, But SPACE Temperature Is Unstable

Thermostat	Thermostat is getting a draft of cold or warm air. Make sure that the wall or hole used to run thermostat wire from the ceiling or basement is sealed, so no draft can come to the thermostat. Faulty Thermostat (Replace).
------------	--

#### C: No water flow

Pump Module	Make sure Pump Module is connected to the control box relay (check all electrical connections). For non-pressurized systems, check water level in Pump Module. If full of water, check pump. Close valve on the pump flanges and loosen pump. Take off pump and see if there is an obstruction in the pump. If pump is defective, replace. For pressurized systems, check loop pressure. Re-pressurize if necessary. May require re-flushing if there is air in the loop.
Solenoid valve	Make sure solenoid valve is connected. Check solenoid. If defective, replace.

## Section 12: Troubleshooting

### D: In heating or cooling mode, unit output is low

Water	Water flow & temperature insufficient.
Airflow	Check speed setting, check nameplate or data manual for proper speed, and correct speed setting. Check for dirty air filter—Clean or replace. Restricted or leaky ductwork. Repair.
Refrigerant charge	Refrigerant charge low, causing inefficient operation. Make adjustments only after airflow and water flow are checked.
Reversing valve	Defective reversing valve can create bypass of refrigerant to suction side of compressor. Switch reversing valve to heating and cooling mode rapidly. If problem is not resolved, replace valve. Wrap the valve with a wet cloth and direct the heat away from the valve. Excessive heat can damage the valve. Always use dry nitrogen when brazing. Replace filter/drier any time the circuit is opened.

### E: In heating or cooling mode, unit output is low

Heat pump will not cool but will heat. Heat pump will not heat but will cool.	Reversing valve does not shift. Check reversing valve wiring. If wired wrong, correct wiring. If reversing valve is stuck, replace valve. Wrap the valve with a wet cloth and direct the heat away from the valve. Excessive heat can damage the valve. Always use dry nitrogen when brazing. Replace filter/drier any time the circuit is opened.
Water heat exchanger	Check for high-pressure drop, or low temperature drop across the coil. It could be scaled. If scaled, clean with condenser coil cleaner.
System undersized	Recalculate conditioning load.

### F: Water heat exchanger freezes in heating mode

Water flow	Low water flow. Increase flow. See F. No water flow.
Flow Switch	Check switch. If defective, replace.

### G: Excessive head pressure in cooling mode

Inadequate water flow	Low water flow, increase flow.
-----------------------	--------------------------------

### H: Excessive head pressure in heating mode

Low air flow	See E: Noisy blower and low air flow.
--------------	---------------------------------------

### I: Air Coil Freezes Over in Cooling Mode

Air flow	See E: Noisy blower and low air flow.
Blower motor	Motor not running or running too slow. Motor tripping off on overload. Check for overheated blower motor and tripped overload. Replace motor if defective.
Panels	Panels not in place.
Low air flow	See E: Noisy blower and low air flow.

### J: Water Dripping from Unit

Unit not level	Level unit.
Condensation drain line plugged	Unplug condensation line.
Water sucking off the air coil in cooling mode	Too much airflow. Duct work not completely installed. If duct work is not completely installed, finish duct work. Check static pressure and compare with air flow chart in spec manual under specific models section. If ductwork is completely installed it may be necessary to reduce CFM.
Water sucking out of the drain pan	Install an EZ-Trap or P-Trap on the drain outlet so blower cannot suck air back through the drain outlet.

## Section 12: Troubleshooting

### O: Compressor won't start

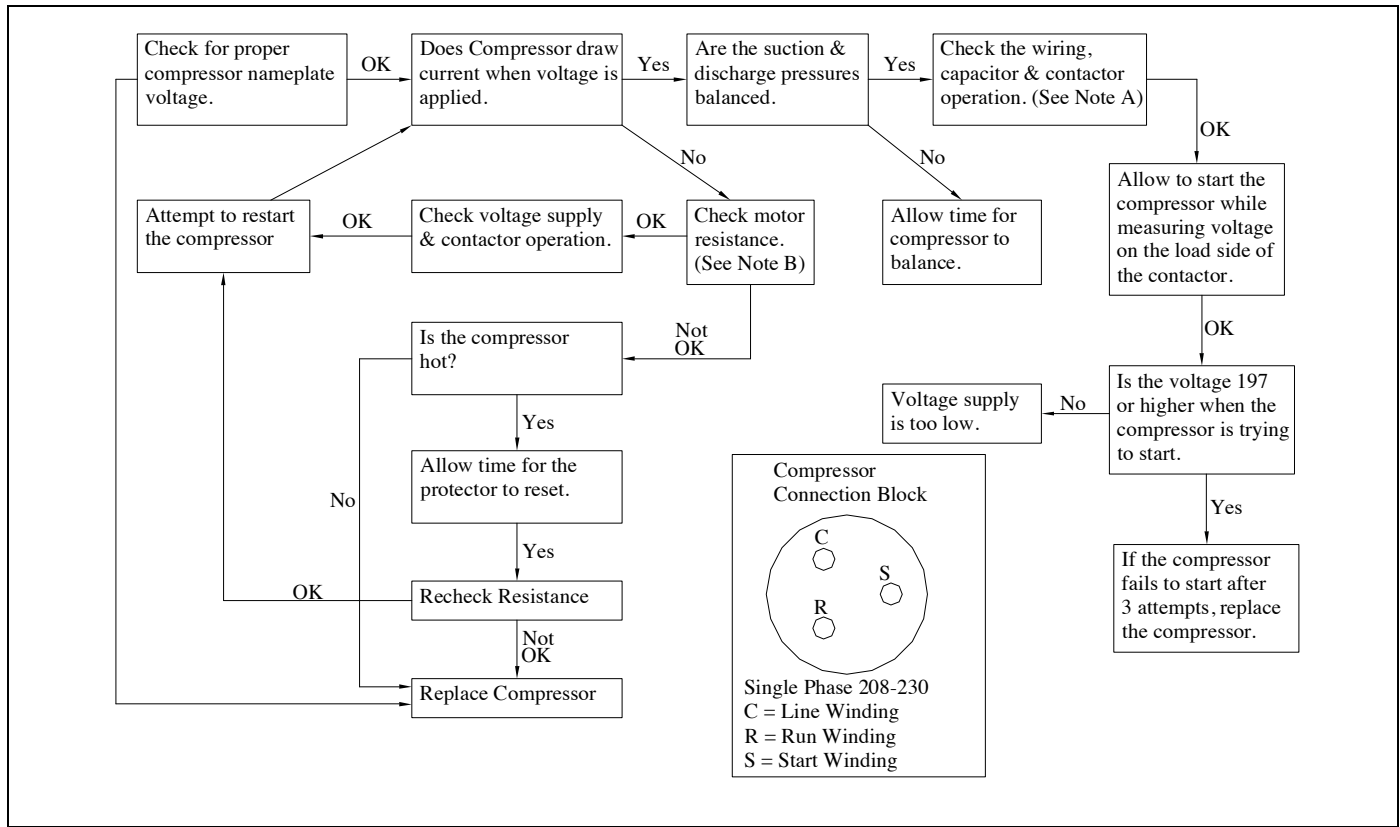

A: Check all terminals, wires & connections for loose or burned wires and connections. Check contactor and 24 Volt coil. Check capacitor connections & check capacitor with capacitor tester.

B: If ohm meter reads 0 (short) resistance from C to S, S to R, R to C or from any one of these terminals to ground (shorted to ground), compressor is bad.

### P: Compressor won't pump chart

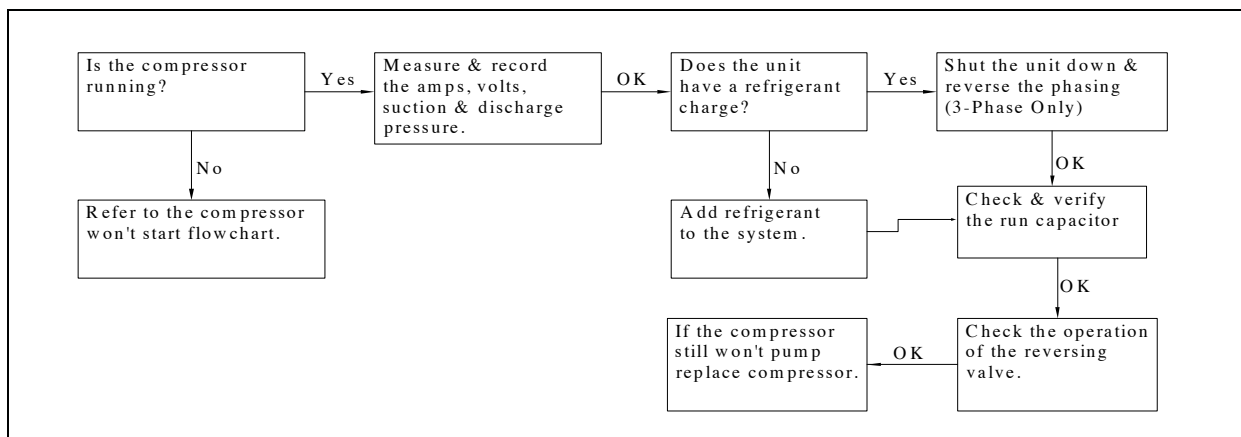

**Section 12: Troubleshooting**

**Model 024 Operational Data - Cooling Mode**

<b>RT024 / AD024 : Full Load Cooling-No Desuperheater Operation</b>							
<b>EWT</b>	<b>Source Flow</b>	<b>Discharge</b>	<b>Suction</b>	<b>Subcooling</b>	<b>Superheat</b>	<b>Source Brine Temp Rise</b>	<b>Air Temp Drop</b>
<b>°F</b>	<b>GPM</b>	<b>PSIG</b>	<b>PSIG</b>	<b>°F</b>	<b>°F</b>	<b>°F</b>	<b>°F</b>
<b>40</b>	<b>3</b>	173 - 213	90 - 110	25 - 29.4	35 - 38.7	15.9 - 19.9	13.3 - 17.3
	<b>4.5</b>	157 - 197	90 - 110	20 - 23.9	37 - 41.4	10.1 - 14.1	13.4 - 17.4
	<b>6</b>	149 - 189	89 - 109	17 - 20.5	37 - 40.7	7.15 - 11.1	13.4 - 17.4
<b>50</b>	<b>3</b>	205 - 245	99 - 119	25 - 28.8	24 - 28.3	16.4 - 20.4	14.3 - 18.3
	<b>4.5</b>	187 - 227	98 - 118	19 - 23.4	26 - 30.3	10.5 - 14.5	14.4 - 18.4
	<b>6</b>	177 - 217	98 - 118	16 - 20.2	26 - 29.8	7.38 - 11.4	14.4 - 18.4
<b>70</b>	<b>3</b>	286 - 326	104 - 124	24 - 27.7	13 - 16.5	16.4 - 20.4	13.9 - 17.9
	<b>4.5</b>	261 - 301	104 - 124	19 - 22.6	14 - 17.6	10.5 - 14.5	14 - 18
	<b>6</b>	248 - 288	104 - 124	15 - 19.4	13 - 17.3	7.4 - 11.4	14 - 18
<b>90</b>	<b>3</b>	390 - 430	108 - 128	26 - 29.7	12 - 16.1	15.7 - 19.7	13.1 - 17.1
	<b>4.5</b>	357 - 397	107 - 127	20 - 24.2	13 - 17.1	10 - 14	13.2 - 17.2
	<b>6</b>	339 - 379	107 - 127	17 - 20.8	13 - 16.8	7.05 - 11	13.2 - 17.2

<b>RT024 / AD024 : Part Load Cooling-No Desuperheater Operation</b>							
<b>EWT</b>	<b>Source Flow</b>	<b>Discharge</b>	<b>Suction</b>	<b>Subcooling</b>	<b>Superheat</b>	<b>Source Brine Temp Rise</b>	<b>Air Temp Drop</b>
<b>°F</b>	<b>GPM</b>	<b>PSIG</b>	<b>PSIG</b>	<b>°F</b>	<b>°F</b>	<b>°F</b>	<b>°F</b>
<b>40</b>	<b>3</b>	147 - 187	88 - 128	14 - 17.7	34 - 37.8	11.5 - 15.5	13.6 - 17.6
	<b>4.5</b>	136 - 176	88 - 128	10 - 14.4	33 - 37.2	7.21 - 11.2	13.6 - 17.6
	<b>6</b>	131 - 171	88 - 128	8.6 - 12.6	34 - 37.9	5 - 9	13.6 - 17.6
<b>50</b>	<b>3</b>	181 - 221	99 - 139	15 - 18.9	16 - 20.3	12.9 - 16.9	14.5 - 18.5
	<b>4.5</b>	168 - 208	99 - 139	11 - 15.3	16 - 20	8.12 - 12.1	14.6 - 18.6
	<b>6</b>	162 - 202	99 - 139	9.4 - 13.4	16 - 20.3	5.69 - 9.69	14.6 - 18.6
<b>70</b>	<b>3</b>	255 - 295	102 - 142	17 - 21	13 - 17.2	12.1 - 16.1	13.7 - 17.7
	<b>4.5</b>	238 - 278	101 - 141	13 - 17	13 - 17	7.62 - 11.6	13.7 - 17.7
	<b>6</b>	229 - 269	101 - 141	11 - 14.9	13 - 17.3	5.31 - 9.31	13.7 - 17.7
<b>90</b>	<b>3</b>	345 - 385	105 - 145	18 - 22	13 - 16.9	11.4 - 15.4	12.8 - 16.8
	<b>4.5</b>	322 - 362	105 - 145	14 - 17.8	13 - 16.6	7.12 - 11.1	12.8 - 16.8
	<b>6</b>	311 - 351	105 - 145	12 - 15.6	13 - 16.9	4.93 - 8.93	12.9 - 16.9



## Section 12: Troubleshooting

### Model 024 Operational Data - Heating Mode

RT024 / AD024 : Full Load Heating-No Desuperheater Operation							
EWT	Source Flow	Discharge	Suction	Subcooling	Superheat	Source Brine Temp Drop	Air Temp Rise
°F	GPM	PSIG	PSIG	°F	°F	°F	°F
30	3	263 - 303	62 - 82	12 - 16.1	4.1 - 8.13	6.98 - 11	17.4 - 21.4
	4.5	268 - 308	67 - 87	11 - 15.2	4.5 - 8.52	4.44 - 8.44	18.2 - 22.2
	6	272 - 312	69 - 89	11 - 14.7	5 - 9.03	2.91 - 6.91	18.8 - 22.8
50	3	294 - 334	93 - 113	7.1 - 11.1	5.7 - 9.66	9.89 - 13.9	23.3 - 27.3
	4.5	299 - 339	100 - 120	6.5 - 10.5	6.1 - 10.1	6.52 - 10.5	24.4 - 28.4
	6	303 - 343	103 - 123	6.2 - 10.2	6.8 - 10.8	4.5 - 8.5	25.1 - 29.1
70	3	331 - 371	128 - 148	2.6 - 6.64	7 - 11	13.2 - 17.2	28.6 - 32.6
	4.5	337 - 377	136 - 156	2.4 - 6.35	7.5 - 11.5	8.92 - 12.9	29.9 - 33.9
	6	341 - 381	141 - 161	2.2 - 6.19	8.3 - 12.3	6.33 - 10.3	30.8 - 34.8
90	3	365 - 405	152 - 172	4.8 - 8.76	15 - 18.6	15.4 - 19.4	32.9 - 36.9
	4.5	372 - 412	162 - 182	4.3 - 8.33	16 - 19.7	10.5 - 14.5	34.4 - 38.4
	6	376 - 416	167 - 187	4.1 - 8.1	17 - 21.1	7.54 - 11.5	35.3 - 39.3

RT024 / AD024 : Part Load Heating-No Desuperheater Operation							
EWT	Source Flow	Discharge	Suction	Subcooling	Superheat	Source Brine Temp Drop	Air Temp Rise
°F	GPM	PSIG	PSIG	°F	°F	°F	°F
30	3	250 - 290	70 - 90	6.8 - 10.8	-1.2 - 2.8	4.29 - 8.29	7.53 - 11.5
	4.5	250 - 290	73 - 93	9.5 - 13.5	0 - 4.05	2.52 - 6.52	8.01 - 12
	6	252 - 292	75 - 95	9 - 13	0.1 - 4.1	1.42 - 5.42	8.21 - 12.2
50	3	278 - 318	103 - 123	3.5 - 7.52	-1 - 3	7.27 - 11.3	10.9 - 14.9
	4.5	278 - 318	107 - 127	5.2 - 7.24	0.6 - 4.56	4.66 - 8.66	11.6 - 15.6
	6	280 - 320	110 - 130	4.9 - 6.93	0.6 - 4.63	3.04 - 7.04	11.8 - 15.8
70	3	311 - 351	139 - 159	2.1 - 4.06	-0.8 - 3.21	10.1 - 14.1	13.9 - 17.9
	4.5	311 - 351	145 - 165	3.3 - 5.32	1.1 - 5.09	6.68 - 10.7	14.7 - 18.7
	6	314 - 354	149 - 169	3.1 - 5.1	1.2 - 5.17	4.57 - 8.57	15 - 19
90	3	356 - 396	169 - 189	-1.2 - 0.81	-0 - 3.98	12.2 - 16.2	15.9 - 19.9
	4.5	355 - 395	177 - 197	-0.9 - 1.06	3.1 - 7.07	8.2 - 12.2	16.8 - 20.8
	6	358 - 398	181 - 201	-1 - 1.02	3.2 - 7.21	5.72 - 9.72	17.1 - 21.1

## Section 12: Troubleshooting

### Model 036 Operational Data - Cooling Mode

RT036 / AD036 : Full Load Cooling-No Desuperheater Operation							
EWT	Source Flow	Liquid	Suction	Subcooling	Superheat	Source Brine Temp Rise	Air Temp Drop
°F	GPM	PSIG	PSIG	°F	°F	°F	°F
40	4.5	163 - 203	94 - 114	14 - 17.7	25 - 28.8	16.8 - 20.8	12.8 - 16.8
	6.75	147 - 187	93 - 113	10 - 14.4	26 - 29.7	10.4 - 14.4	12.8 - 16.8
	9	140 - 180	93 - 113	8.6 - 12.6	25 - 29.3	7.4 - 11.4	12.9 - 16.9
50	4.5	200 - 240	100 - 120	19 - 22.8	9.9 - 13.9	16.9 - 20.9	13.1 - 17.1
	6.75	181 - 221	99 - 119	14 - 18.4	10 - 14.3	10.5 - 14.5	13.2 - 17.2
	9	172 - 212	99 - 119	12 - 16.1	10 - 14.1	7.46 - 11.5	13.2 - 17.2
70	4.5	282 - 322	102 - 122	21 - 25	8.2 - 12.2	16.4 - 20.4	12.5 - 16.5
	6.75	256 - 296	101 - 121	16 - 20.2	8.6 - 12.6	10.1 - 14.1	12.5 - 16.5
	9	244 - 284	101 - 121	14 - 17.6	8.4 - 12.4	7.19 - 11.2	12.6 - 16.6
90	4.5	379 - 419	105 - 125	22 - 26	7.6 - 11.6	15.4 - 19.4	11.5 - 15.5
	6.75	345 - 385	104 - 124	17 - 21	7.9 - 11.9	9.48 - 13.5	11.6 - 15.6
	9	329 - 369	104 - 124	14 - 18.3	7.8 - 11.8	6.7 - 10.7	11.6 - 15.6

RT036 / AD036 : Part Load Cooling-No Desuperheater Operation							
EWT	Source Flow	Liquid	Suction	Subcooling	Superheat	Source Brine Temp Rise	Air Temp Drop
°F	GPM	PSIG	PSIG	°F	°F	°F	°F
40	4.5	146 - 186	97 - 137	5.8 - 9.84	18 - 21.8	12.2 - 16.2	12.7 - 16.7
	6.75	136 - 176	97 - 137	4.2 - 8.2	19 - 22.7	7.6 - 11.6	12.8 - 16.8
	9	131 - 171	97 - 137	3.3 - 7.3	19 - 23.2	5.3 - 9.3	12.7 - 16.7
50	4.5	181 - 221	102 - 142	12 - 16.3	8.6 - 12.6	13 - 17	12.9 - 16.9
	6.75	168 - 208	101 - 141	9.3 - 13.3	9.1 - 13.1	8.13 - 12.1	12.9 - 16.9
	9	162 - 202	101 - 141	7.7 - 11.7	9.4 - 13.4	5.71 - 9.71	12.9 - 16.9
70	4.5	253 - 293	104 - 144	14 - 18.3	7.5 - 11.5	12.1 - 16.1	12.1 - 16.1
	6.75	236 - 276	103 - 143	11 - 14.9	8 - 12	7.53 - 11.5	12.1 - 16.1
	9	227 - 267	103 - 143	9 - 13	8.2 - 12.2	5.25 - 9.25	12.1 - 16.1
90	4.5	341 - 381	107 - 147	15 - 19.1	6.5 - 10.5	11.8 - 15.8	11.2 - 15.2
	6.75	318 - 358	106 - 146	12 - 15.6	6.9 - 10.9	7.33 - 11.3	11.2 - 15.2
	9	307 - 347	106 - 146	9.6 - 13.6	7.1 - 11.1	5.1 - 9.1	11.2 - 15.2

## Section 12: Troubleshooting

### Model 036 Operational Data - Heating Mode

RT036 / AD036 : Full Load Heating-No Desuperheater Operation							
EWT	Source Flow	Liquid	Suction	Subcooling	Superheat	Source Brine Temp Drop	Air Temp Rise
°F	GPM	PSIG	PSIG	°F	°F	°F	°F
30	4.5	252 - 292	61 - 81	21 - 25	7.2 - 11.2	7.41 - 11.4	15.2 - 19.2
	6.75	256 - 296	66 - 86	21 - 24.6	8.7 - 12.7	4.22 - 8.22	16.1 - 20.1
	9	257 - 297	70 - 90	12 - 16.4	5.2 - 9.25	2.98 - 6.98	16.6 - 20.6
50	4.5	272 - 312	91 - 111	11 - 14.7	5.3 - 9.26	10.8 - 14.8	20.5 - 24.5
	6.75	277 - 317	98 - 118	11 - 14.5	6.4 - 10.4	6.47 - 10.5	21.7 - 25.7
	9	278 - 318	103 - 123	5.9 - 9.94	3.7 - 7.73	4.79 - 8.79	22.3 - 26.3
70	4.5	315 - 355	125 - 145	11 - 15.2	7.2 - 11.2	14.6 - 18.6	26.2 - 30.2
	6.75	320 - 360	134 - 154	11 - 15	8.7 - 12.7	8.96 - 13	27.6 - 31.6
	9	322 - 362	141 - 161	6.2 - 10.2	5.3 - 9.29	6.78 - 10.8	28.4 - 32.4
90	4.5	329 - 369	160 - 180	0.7 - 4.67	12 - 16.1	18.1 - 22.1	31.1 - 35.1
	6.75	335 - 375	171 - 191	0.6 - 4.63	14 - 18.4	11.3 - 15.3	32.9 - 36.9
	9	336 - 376	181 - 201	-0.3 - 3.67	9.1 - 13.1	8.66 - 12.7	33.8 - 37.8

RT036 / AD036 : Part Load Heating-No Desuperheater Operation							
EWT	Source Flow	Liquid	Suction	Subcooling	Superheat	Source Brine Temp Drop	Air Temp Rise
°F	GPM	PSIG	PSIG	°F	°F	°F	°F
30	4.5	231 - 271	67 - 87	7.5 - 11.5	9.5 - 13.5	4.53 - 8.53	7.53 - 11.5
	6.75	233 - 273	70 - 90	6.6 - 10.6	9.7 - 13.7	2.56 - 6.56	7.89 - 11.9
	9	235 - 275	72 - 92	6.6 - 10.6	10 - 14.2	1.41 - 5.41	8.11 - 12.1
50	4.5	248 - 288	99 - 119	6.5 - 10.5	7 - 11	7.38 - 11.4	11 - 15
	6.75	251 - 291	105 - 125	5.7 - 7.7	7.1 - 11.1	4.54 - 8.54	11.5 - 15.5
	9	253 - 293	106 - 126	5.7 - 7.68	7.5 - 11.5	2.89 - 6.89	11.8 - 15.8
70	4.5	282 - 322	137 - 157	3.9 - 5.87	7.5 - 11.5	10.1 - 14.1	14.7 - 18.7
	6.75	285 - 325	145 - 165	3.3 - 5.33	7.6 - 11.6	6.47 - 10.5	15.3 - 19.3
	9	287 - 327	147 - 167	3.3 - 5.32	8 - 12	4.33 - 8.33	15.7 - 19.7
90	4.5	307 - 347	177 - 197	-1.9 - 0.09	11 - 15.2	13.1 - 17.1	17.9 - 21.9
	6.75	310 - 350	187 - 207	-1.9 - 0.08	11 - 15.4	8.56 - 12.6	18.7 - 22.7
	9	313 - 353	189 - 209	-1.9 - 0.08	12 - 16	5.89 - 9.89	19.1 - 23.1

**Section 12: Troubleshooting**

**Model 048 Operational Data - Cooling Mode**

<b>RT048 / AD048 : Full Load Cooling-No Desuperheater Operation</b>							
<b>EWT</b>	<b>Source Flow</b>	<b>Discharge</b>	<b>Suction</b>	<b>Subcooling</b>	<b>Superheat</b>	<b>Source Brine Temp Rise</b>	<b>Air Temp Drop</b>
<b>°F</b>	<b>GPM</b>	<b>PSIG</b>	<b>PSIG</b>	<b>°F</b>	<b>°F</b>	<b>°F</b>	<b>°F</b>
<b>40</b>	<b>6</b>	177 - 217	87 - 107	26 - 29.7	36 - 40.5	15.7 - 19.7	11.4 - 15.4
	<b>9</b>	160 - 200	87 - 107	20 - 24.1	39 - 42.9	9.86 - 13.9	11.5 - 15.5
	<b>12</b>	152 - 192	86 - 106	17 - 21.2	41 - 45.3	6.88 - 10.9	11.5 - 15.5
<b>50</b>	<b>6</b>	215 - 255	97 - 117	26 - 30.1	24 - 28.3	17.6 - 21.6	12.4 - 16.4
	<b>9</b>	195 - 235	96 - 116	20 - 24.4	26 - 30	11.1 - 15.1	12.5 - 16.5
	<b>12</b>	185 - 225	96 - 116	17 - 21.4	28 - 31.6	7.83 - 11.8	12.6 - 16.6
<b>70</b>	<b>6</b>	295 - 335	103 - 123	24 - 28.4	13 - 16.6	16.6 - 20.6	12.1 - 16.1
	<b>9</b>	269 - 309	102 - 122	19 - 23	13 - 17.5	10.5 - 14.5	12.2 - 16.2
	<b>12</b>	255 - 295	102 - 122	16 - 20.2	14 - 18.4	7.34 - 11.3	12.3 - 16.3
<b>90</b>	<b>6</b>	399 - 439	105 - 125	27 - 30.5	11 - 14.6	16.2 - 20.2	11.2 - 15.2
	<b>9</b>	363 - 403	105 - 125	21 - 24.7	11 - 15.4	10.2 - 14.2	11.2 - 15.2
	<b>12</b>	345 - 385	104 - 124	18 - 21.7	12 - 16.2	7.15 - 11.1	11.3 - 15.3

<b>RT048 / AD048 : Part Load Cooling-No Desuperheater Operation</b>							
<b>EWT</b>	<b>Source Flow</b>	<b>Discharge</b>	<b>Suction</b>	<b>Subcooling</b>	<b>Superheat</b>	<b>Source Brine Temp Rise</b>	<b>Air Temp Drop</b>
<b>°F</b>	<b>GPM</b>	<b>PSIG</b>	<b>PSIG</b>	<b>°F</b>	<b>°F</b>	<b>°F</b>	<b>°F</b>
<b>40</b>	<b>6</b>	152 - 192	91 - 131	13 - 17.4	32 - 36	10.6 - 14.6	12.3 - 16.3
	<b>9</b>	141 - 181	90 - 130	10 - 14.1	32 - 35.6	6.61 - 10.6	12.5 - 16.5
	<b>12</b>	135 - 175	90 - 130	8.8 - 12.8	34 - 38.3	4.22 - 8.22	12.4 - 16.4
<b>50</b>	<b>6</b>	185 - 225	98 - 138	15 - 19.3	15 - 18.8	10.7 - 14.7	12.8 - 16.8
	<b>9</b>	172 - 212	97 - 137	12 - 15.7	15 - 18.6	6.69 - 10.7	13 - 17
	<b>12</b>	164 - 204	97 - 137	10 - 14.2	16 - 19.9	4.28 - 8.28	12.9 - 16.9
<b>70</b>	<b>6</b>	261 - 301	100 - 140	18 - 21.8	12 - 16.1	10.6 - 14.6	12.1 - 16.1
	<b>9</b>	243 - 283	100 - 140	14 - 17.6	12 - 15.9	6.67 - 10.7	12.2 - 16.2
	<b>12</b>	233 - 273	100 - 140	12 - 15.9	13 - 17	4.27 - 8.27	12.2 - 16.2
<b>90</b>	<b>6</b>	349 - 389	102 - 142	20 - 23.7	12 - 16.5	9.88 - 13.9	11 - 15
	<b>9</b>	326 - 366	102 - 142	15 - 19.1	12 - 16.3	6.14 - 10.1	11.1 - 15.1
	<b>12</b>	312 - 352	102 - 142	13 - 17.2	13 - 17.5	3.89 - 7.89	11.1 - 15.1

## Section 12: Troubleshooting

### Model 048 Operational Data - Heating Mode

RT048 / AD048 : Full Load Heating-No Desuperheater Operation							
EWT	Source Flow	Discharge	Suction	Subcooling	Superheat	Source Brine Temp Drop	Air Temp Rise
°F	GPM	PSIG	PSIG	°F	°F	°F	°F
30	6	264 - 304	60 - 80	23 - 27.2	4.4 - 8.38	7.54 - 11.5	16 - 20
	9	266 - 306	65 - 85	19 - 22.9	4.8 - 8.83	4.7 - 8.7	16.8 - 20.8
	12	267 - 307	68 - 88	15 - 18.7	4.5 - 8.46	2.93 - 6.93	17.3 - 21.3
50	6	279 - 319	90 - 110	13 - 16.7	5.5 - 9.47	10.5 - 14.5	21.2 - 25.2
	9	281 - 321	96 - 116	10 - 14.2	6 - 10	6.77 - 10.8	22.3 - 26.3
	12	282 - 322	101 - 121	7.7 - 11.7	5.6 - 9.56	4.45 - 8.45	22.9 - 26.9
70	6	302 - 342	122 - 142	7.5 - 11.5	8.1 - 12.1	14.7 - 18.7	26.5 - 30.5
	9	304 - 344	131 - 151	5.9 - 9.86	8.8 - 12.8	9.73 - 13.7	27.7 - 31.7
	12	306 - 346	138 - 158	4.3 - 8.26	8.2 - 12.2	6.63 - 10.6	28.6 - 32.6
90	6	320 - 360	150 - 170	4.8 - 8.84	15 - 18.6	17.5 - 21.5	30.9 - 34.9
	9	323 - 363	161 - 181	3.7 - 7.68	16 - 19.8	11.7 - 15.7	32.4 - 36.4
	12	324 - 364	169 - 189	2.5 - 6.53	15 - 18.8	8.05 - 12.1	33.3 - 37.3

RT048 / AD048 : Part Load Heating-No Desuperheater Operation							
EWT	Source Flow	Discharge	Suction	Subcooling	Superheat	Source Brine Temp Drop	Air Temp Rise
°F	GPM	PSIG	PSIG	°F	°F	°F	°F
30	6	245 - 285	71 - 91	8.1 - 12.1	2.1 - 6.07	3.96 - 7.96	8.33 - 12.3
	9	248 - 288	74 - 94	7.8 - 11.8	3 - 6.97	2.25 - 6.25	8.69 - 12.7
	12	251 - 291	79 - 99	4.8 - 8.77	1.6 - 5.62	0.97 - 4.97	9.08 - 13.1
50	6	260 - 300	103 - 123	4.8 - 8.77	3.3 - 7.32	6.99 - 11	11.7 - 15.7
	9	262 - 302	107 - 127	4.6 - 6.57	4.5 - 8.5	4.41 - 8.41	12.1 - 16.1
	12	266 - 306	114 - 134	2.5 - 4.55	2.7 - 6.72	2.48 - 6.48	12.6 - 16.6
70	6	283 - 323	144 - 164	-0.7 - 1.33	3.1 - 7.11	9.3 - 13.3	15.2 - 19.2
	9	286 - 326	149 - 169	-0.7 - 1.29	4.2 - 8.24	6.05 - 10.1	15.8 - 19.8
	12	289 - 329	159 - 179	-1.1 - 0.9	2.5 - 6.53	3.63 - 7.63	16.5 - 20.5
90	6	308 - 348	180 - 200	-1.4 - 0.64	6.5 - 10.5	11.8 - 15.8	18.3 - 22.3
	9	311 - 351	187 - 207	-1.4 - 0.62	8.4 - 12.4	7.82 - 11.8	19 - 23
	12	315 - 355	199 - 219	-1.6 - 0.43	5.6 - 9.59	4.86 - 8.86	19.8 - 23.8

## Section 12: Troubleshooting

### Model 060 Operational Data - Cooling Mode

RT060 / AD060 : Full Load Cooling-No Desuperheater Operation							
EWT	Source Flow	Discharge	Suction	Subcooling	Superheat	Source Brine Temp Rise	Air Temp Drop
°F	GPM	PSIG	PSIG	°F	°F	°F	°F
40	7.5	158 - 198	76 - 96	19 - 23	38 - 42.2	14.1 - 18.1	12.6 - 16.6
	11.25	143 - 183	75 - 95	14 - 18.1	40 - 43.8	8.65 - 12.6	12.7 - 16.7
	15	136 - 176	75 - 95	12 - 15.5	40 - 44.4	6.05 - 10.1	12.7 - 16.7
50	7.5	193 - 233	85 - 105	20 - 24.5	26 - 29.9	14.9 - 18.9	14 - 18
	11.25	175 - 215	85 - 105	15 - 19.2	27 - 31	9.21 - 13.2	14.1 - 18.1
	15	166 - 206	85 - 105	12 - 16.5	27 - 31.4	6.47 - 10.5	14.2 - 18.2
70	7.5	273 - 313	94 - 114	20 - 24.1	8.9 - 12.9	15.4 - 19.4	13.9 - 17.9
	11.25	248 - 288	93 - 113	15 - 18.9	9.4 - 13.4	9.54 - 13.5	14 - 18
	15	236 - 276	93 - 113	12 - 16.2	9.5 - 13.5	6.73 - 10.7	14 - 18
90	7.5	369 - 409	96 - 116	21 - 24.8	8.3 - 12.3	14.5 - 18.5	12.7 - 16.7
	11.25	336 - 376	95 - 115	15 - 19.4	8.7 - 12.7	8.94 - 12.9	12.8 - 16.8
	15	320 - 360	95 - 115	13 - 16.7	8.8 - 12.8	6.27 - 10.3	12.9 - 16.9

RT060 / AD060 : Part Load Cooling-No Desuperheater Operation							
EWT	Source Flow	Discharge	Suction	Subcooling	Superheat	Source Brine Temp Rise	Air Temp Drop
°F	GPM	PSIG	PSIG	°F	°F	°F	°F
40	7.5	141 - 181	81 - 121	9.9 - 13.9	31 - 34.5	10.4 - 14.4	12.3 - 16.3
	11.25	130 - 170	81 - 121	7 - 11	31 - 35.1	6.22 - 10.2	12.3 - 16.3
	15	126 - 166	81 - 121	5.8 - 9.83	33 - 37.2	4.36 - 8.36	12.3 - 16.3
50	7.5	173 - 213	93 - 133	10 - 14	11 - 15.1	11.4 - 15.4	13.3 - 17.3
	11.25	160 - 200	92 - 132	7.1 - 11.1	11 - 15.3	6.91 - 10.9	13.3 - 17.3
	15	155 - 195	92 - 132	5.9 - 9.89	12 - 16.1	4.9 - 8.9	13.3 - 17.3
70	7.5	247 - 287	95 - 135	14 - 17.7	7.6 - 11.6	10.9 - 14.9	12.5 - 16.5
	11.25	229 - 269	95 - 135	9.9 - 13.9	7.7 - 11.7	6.56 - 10.6	12.6 - 16.6
	15	222 - 262	94 - 134	8.3 - 12.3	8.4 - 12.4	4.63 - 8.63	12.6 - 16.6
90	7.5	333 - 373	97 - 137	14 - 18.5	7.5 - 11.5	10.1 - 14.1	11.3 - 15.3
	11.25	310 - 350	97 - 137	10 - 14.5	7.6 - 11.6	6.02 - 10	11.3 - 15.3
	15	301 - 341	97 - 137	8.9 - 12.9	8.2 - 12.2	4.21 - 8.21	11.3 - 15.3



## Section 12: Troubleshooting

### Model 060 Operational Data - Heating Mode

RT060 / AD060 : Full Load Heating-No Desuperheater Operation							
EWT	Source Flow	Discharge	Suction	Subcooling	Superheat	Source Brine Temp Drop	Air Temp Rise
°F	GPM	PSIG	PSIG	°F	°F	°F	°F
30	7.5	272 - 312	61 - 81	19 - 23	1.4 - 5.37	6.87 - 10.9	21.6 - 25.6
	11.25	275 - 315	66 - 86	12 - 16	1.8 - 5.78	4.11 - 8.11	22.4 - 26.4
	15	276 - 316	68 - 88	6.5 - 10.5	1.6 - 5.58	2.63 - 6.63	23.1 - 27.1
50	7.5	298 - 338	91 - 111	5.7 - 9.66	2.7 - 6.67	10 - 14	28.2 - 32.2
	11.25	301 - 341	97 - 117	3.1 - 7.09	3.2 - 7.24	6.28 - 10.3	29.3 - 33.3
	15	303 - 343	101 - 121	1.1 - 5.11	3 - 6.97	4.26 - 8.26	30.2 - 34.2
70	7.5	322 - 362	124 - 144	-0.9 - 3.07	7.3 - 11.3	13.4 - 17.4	35.1 - 39.1
	11.25	325 - 365	133 - 153	-1.3 - 2.71	8.5 - 12.5	8.58 - 12.6	36.5 - 40.5
	15	327 - 367	138 - 158	-1.6 - 2.43	7.9 - 11.9	6.01 - 10	37.5 - 41.5
90	7.5	346 - 386	150 - 170	-1.3 - 2.66	15 - 19.1	15.9 - 19.9	41.1 - 45.1
	11.25	349 - 389	160 - 180	-1.6 - 2.44	17 - 21.1	10.4 - 14.4	42.7 - 46.7
	15	351 - 391	166 - 186	-1.7 - 2.27	16 - 20.1	7.36 - 11.4	43.9 - 47.9

RT060 / AD060 : Part Load Heating-No Desuperheater Operation							
EWT	Source Flow	Discharge	Suction	Subcooling	Superheat	Source Brine Temp Drop	Air Temp Rise
°F	GPM	PSIG	PSIG	°F	°F	°F	°F
30	7.5	244 - 284	70 - 90	-5.7 - -1.7	0.1 - 4.12	4.37 - 8.37	8.1 - 12.1
	11.25	247 - 287	74 - 94	-4.5 - -0.5	0.1 - 4.13	2.32 - 6.32	8.47 - 12.5
	15	247 - 287	75 - 95	-4.2 - -0.2	0.4 - 4.42	1.5 - 5.5	8.52 - 12.5
50	7.5	268 - 308	102 - 122	-3.3 - 0.65	0.9 - 4.92	7.09 - 11.1	11.5 - 15.5
	11.25	272 - 312	108 - 128	-2.9 - -0.9	0.9 - 4.95	4.16 - 8.16	12 - 16
	15	272 - 312	109 - 129	-2.8 - -0.8	1.3 - 5.34	2.99 - 6.99	12.1 - 16.1
70	7.5	291 - 331	137 - 157	-2.2 - -0.2	2.6 - 6.62	9.82 - 13.8	14.7 - 18.7
	11.25	295 - 335	144 - 164	-2.1 - -0.1	2.7 - 6.66	6.02 - 10	15.3 - 19.3
	15	295 - 335	146 - 166	-2.1 - -0.1	3.3 - 7.27	4.5 - 8.5	15.4 - 19.4
90	7.5	311 - 351	175 - 195	-2.1 - -0.1	4.3 - 8.3	12.6 - 16.6	18.1 - 22.1
	11.25	315 - 355	184 - 204	-2.1 - -0.1	4.3 - 8.35	7.9 - 11.9	18.8 - 22.8
	15	315 - 355	187 - 207	-2 - 0	5.2 - 9.19	6.02 - 10	18.9 - 22.9

## Section 12: Troubleshooting

**Table 13: Refrigeration Troubleshooting**

System Faults	Mode	Discharge Pressure	Suction Pressure	Superheat	Subcooling	Air TD	Water TD	Compressor Amps
Under Charge	Heat	Low	Low	High	Low	Low	Low	Low
	Cool	Low	Low	High	Low	Low	Low	Low
Over Charge	Heat	High	High/Normal	Normal	High	High	Normal	High
	Cool	High	High/Normal	Normal	High	Normal	High	High
Low Air Flow	Heat	High	High/Normal	Normal	High/Normal	High	Low	High
	Cool	Low	Low/Normal	Low	Normal	High	Low	High/Normal
Low Source Water Flow	Heat	Low	Low/Normal	Low	Normal	High	Low	High/Normal
	Cool	High	High/Normal	Normal	High/Normal	High	Low	High
Low Load Water Flow	Heat	High	High/Normal	Normal	High/Normal	High	Low	High
	Cool	Low	Low/Normal	Low	Normal	High	Low	High/Normal
Restricted TXV	Heat	High	Low	High	High	Low	Low	Low
	Cool	High	Low	High	High	Low	Low	Low
TXV Stuck Open	Heat	Low	High/Normal	Low	Low	Low	Low	High
	Cool	Low	High/Normal	Low	Low	Low	Low	High
Inadequate Compression	Heat	Low	High	High/Normal	Low/Normal	Low	Low	Low
	Cool	Low	High	High/Normal	Low/Normal	Low	Low	Low

### Superheat/Subcooling Conditions

Superheat	Subcooling	Condition
Normal	Normal	Normal operation
Normal	High	Overcharged
High	Low	Undercharged
High	High	Restriction or TXV is stuck almost closed
Low	Low	TXV is stuck open

# Section 13: Troubleshooting Form

## Troubleshooting Form

Customer/Job Name: .....

Date: .....

Model #: .....

Serial #: .....

Antifreeze Type: .....

$HE \text{ or } HR = GPM \times TD \times \text{Fluid Factor}$   
 (Use 500 for water; 485 for antifreeze)

$SH = \text{Suction Temp.} - \text{Suction Sat.}$   
 $SC = \text{Disch. Sat.} - \text{Liq. Line Temp.}$

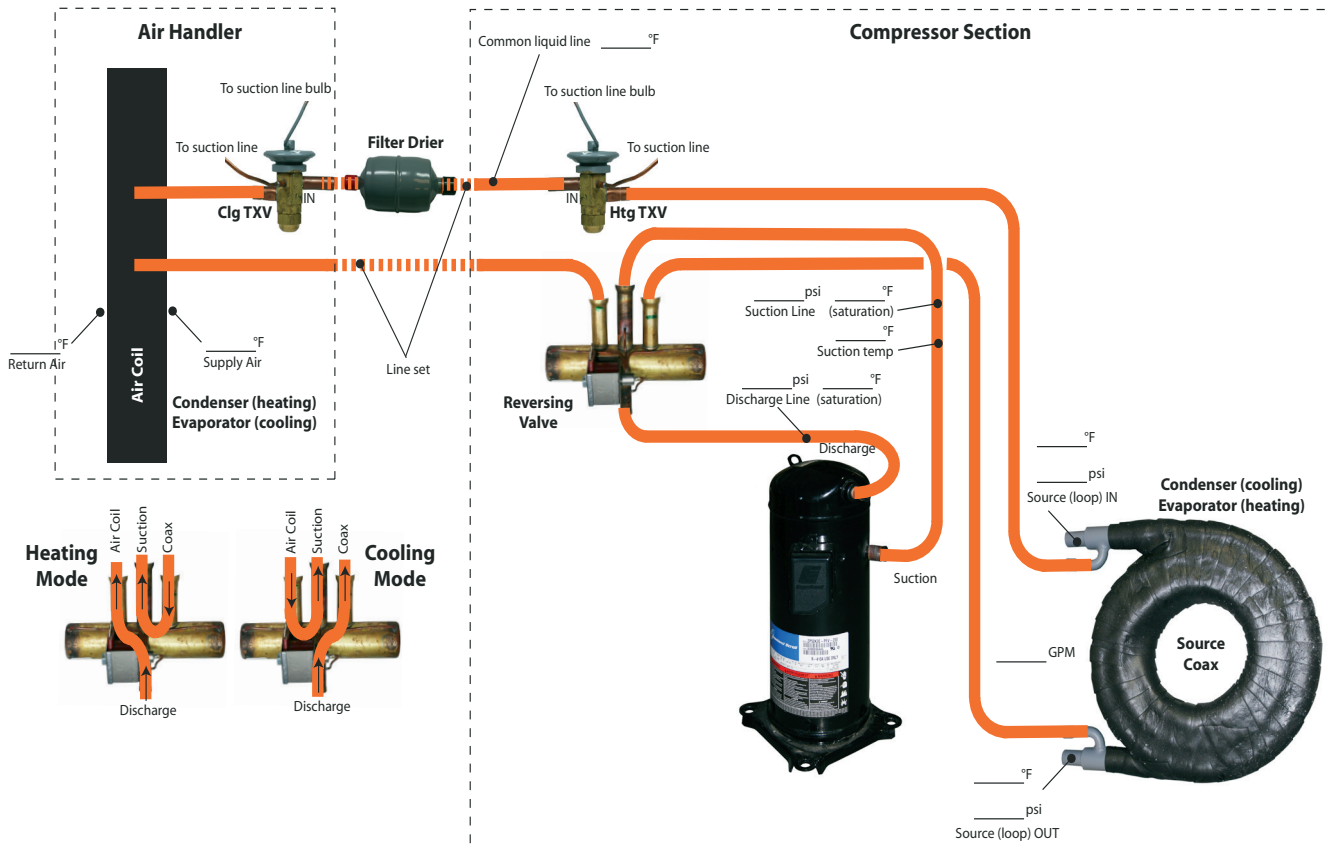

## Section 14: Electrical Data

### Unit Electrical Data

Model	Voltage Code/ HWG Option	60 Hz Power		Compressor		Fan Motor FLA	HWG Pump FLA	Ext. Loop Pump FLA	Total Unit FLA	Min Circuit AMPS	Max Brkr HACR
		Volts	Phase	LRA	RLA						
RT024	00	208/230	1	58.3	11.7	0.0	0.0	4.0	15.7	18.6	30
	10	208/230	1	58.3	11.7	0.0	0.0	4.0	15.7	18.6	30
RT036	00	208/230	1	83.0	15.6	0.0	0.0	4.0	19.6	23.5	35
	10	208/230	1	83.0	15.6	0.0	0.0	4.0	19.6	23.5	35
RT048	00	208/230	1	104.0	21.2	0.0	0.0	5.5	26.7	32.0	50
	10	208/230	1	104.0	21.2	0.0	0.0	5.5	26.7	32.0	50
RT060	00	208/230	1	152.9	27.1	0.0	0.0	5.5	32.6	39.4	60
	10	208/230	1	152.9	27.1	0.0	0.0	5.5	32.6	39.4	60

#### Notes:

1. All line and low voltage wiring must adhere to the National Electrical Code and local codes, whichever is the most stringent.
2. In determining the correct supply wire size and maximum length, reference NFPA 70, Section 310. If the calculation is close to the maximum allowable ampacity of a particular wire size, use the next size up. This will ensure that no adverse effects occur, such as light dimming and/or shortened compressor life.
3. Min/Max Voltage: 208/230/60 = 187-252

\*The external loop pump FLA is based on a maximum of three UP26-116F-230V pumps (1/2hp) for 048-060 and two pumps for 024-036.

#### Note: Proper Power Supply Evaluation

When any compressor bearing unit is connected to a weak power supply, starting current will generate a significant “sag” in the voltage which reduces the starting torque of the compressor motor and increases the start time. This will influence the rest of the electrical system in the building by lowering the voltage to the lights. This momentary low voltage causes “light dimming”. The total electrical system should be evaluated with an electrician and HVAC technician. The evaluation should include all connections, sizes of wires, and size of the distribution panel between the unit and the utility’s connection. The transformer connection and sizing should be evaluated by the electric utility provider.

## Section 16: Specification Glossary & Calculations

### Glossary of Terms

CFM = Airflow, Cubic Feet/Minute	HR = Total Heat Of Rejection, Btu/hr
COP = Coefficient of Performance = BTU Output / BTU Input	KW = Total Power Unit Input, Kilowatts
EAT = Entering Air Temperature, Fahrenheit (Dry Bulb/Wet Bulb)	LAT = Leaving Air Temperature, Fahrenheit
EER = Energy Efficiency Ratio = BTU output/Watts input	LC = Latent Cooling Capacity, Btu/hr
EWT = Entering Source Water Temperature, Fahrenheit	SC = Sensible Cooling Capacity, Btu/hr
ELT = Entering Load Water Temperature, Fahrenheit	LWT = Leaving Source Water Temperature, Fahrenheit
GPM = Water Flow, Gallons Per Minute	LLT = Leaving Load Water Temperature, Fahrenheit
HC = Total Heating Capacity, Btu/hr	TC = Total Cooling Capacity, Btu/hr
HE = Total Heat Of Extraction, Btu/hr	WPD = Water Pressure Drop, PSI & Feet of Water

### Heating & Cooling Calculations

Heating	Cooling
$LAT = EAT + \frac{HC}{CFM \times 1.08}$	$LAT (DB) = EAT (DB) - \frac{SC}{CFM \times 1.08}$
$LWT = EWT - \frac{HE}{GPM \times 500}$	$LWT = EWT + \frac{HR}{GPM \times 500}$
$LC = TC - SC$	

## Section 15: Specification Glossary & Calculations

### Water Flow Selection

Proper flow rate is crucial for reliable operation of geothermal heat pumps. The performance data shows three flow rates for each entering water temperature (EWT column). The general “rule of thumb” when selecting flow rates is the following:

Top flow rate: Reference low flow rate.

Middle flow rate: Minimum closed loop system flow rate (2.25 to 2.50 gpm/ton)

Bottom flow rate: Nominal (optimum) closed loop system flow rate (3.0 gpm/ton)

Although the “rule of thumb” is adequate in most areas of North America, it is important to consider the application type before applying this “rule of thumb.” Antifreeze is generally required for all closed loop (geothermal) applications.

Extreme Southern U.S. locations are the only exception. Open loop (well water) systems cannot use antifreeze, and must have enough flow rate in order to avoid freezing conditions at the Leaving Source Water Temperature (LWT) connection.

Calculations must be made for all systems without antifreeze to determine if the top flow rate is adequate to prevent LWT at or near freezing conditions. The following steps should taken in making this calculation:

Determine minimum EWT based upon your geographical area. Go to the performance data table for the heat pump model selected and look up the the Heat of Extraction (HE) at the “rule of thumb” water flow rate (GPM) and at the design Entering Air Temperature (EAT).

Calculate the temperature difference (TD) based upon the HE and GPM of the model (step 4).

$$TD = HE / (GPM \times 500).$$

Calculate the LWT (step 6).

$$LWT = EWT - TD.$$

If the LWT is below 35-38°F, there is potential for freezing conditions if the flow rate or water temperature is less than ideal conditions, and the flow rate must be increased.

Example 1:

$$EWT = 50^{\circ}\text{F}.$$

3-Ton Model, high capacity. Flow rate = 6.8 GPM. HE = 26,300 Btuh.

$$TD = 26,300 / (6.8 \times 500) = 7.7^{\circ}\text{F}$$

$$LWT = 50 - 7.7 = 42.3^{\circ}\text{F}$$

Water flow rate should be adequate under these conditions.

Example 2:

$$EWT = 40^{\circ}\text{F}.$$

3-Ton Model, high capacity. Flow rate = 6.8 GPM. HE = 22,700 Btuh.

$$TD = 22,700 / (6.8 \times 500) = 6.7^{\circ}\text{F}$$

$$LWT = 40 - 6.7 = 33.3^{\circ}\text{F}$$

Water flow rate must be increased.

## Section 16: Performance Data Correction Factors

### Heating Correction Factors

EAT °F	HC	HE	kW
50	1.0450	1.1136	0.8208
55	1.0347	1.0893	0.8567
60	1.0260	1.0640	0.9019
65	1.0089	1.0270	0.9497
70	1.0000	1.0000	1.0000
75	0.9924	0.9741	1.0527
80	0.9870	0.9653	1.0522

### Cooling Correction Factors

EAT (WB) °F	TC	HR	kW
55	0.8215	0.8293	0.8635
60	0.8955	0.9001	0.9205
63	0.9404	0.9431	0.9547
65	0.9701	0.9715	0.9774
67	1.0000	1.0000	1.0000
70	1.0446	1.0425	1.0335
75	1.1179	1.1124	1.0878

### Sensible Cooling Correction Factors

EAT (WB) °F	EAT (DB) °F				
	70	75	80	85	90
55	1.201	1.289			
60	0.943	1.067	1.192		
63	0.852	0.995	1.138		
65	0.797	0.952	1.106	1.261	
67	0.624	0.812	1.000	1.188	1.343
70		0.697	0.820	0.944	1.067
75			0.637	0.817	0.983

**This page left blank for Warranty Form detachment.**

**Warranty Claim(s)**

For warranty claims, the Installer/Dealer can visit: <http://warranty-claim.enertechgeo.com>



**Section 17: Warranty Information/Forms**

**Warranty Claim(s)**

For warranty claims, the Installer/Dealer can visit: <http://warranty-claim.enertechgeo.com>

**Warranty Registration Form**



# WARRANTY REGISTRATION

NOW REGISTER ONLINE AT [WARRANTY-REGISTRATION.ENERTECHGEO.COM](http://WARRANTY-REGISTRATION.ENERTECHGEO.COM)

**WARRANTY REGISTRATIONS SHOULD BE SUBMITTED WITHIN 60 DAYS OF INSTALLATION**

Model Number \_\_\_\_\_ Serial Number \_\_\_\_\_ Install Date \_\_\_\_\_

This unit is performing  Satisfactorily  Not Satisfactorily (please explain) \_\_\_\_\_

\_\_\_\_\_

Purchaser/User Name \_\_\_\_\_ Phone \_\_\_\_\_

Address \_\_\_\_\_ City \_\_\_\_\_ State/Prov \_\_\_\_\_

Postal Code \_\_\_\_\_ Email \_\_\_\_\_

Installer Company Name \_\_\_\_\_

City \_\_\_\_\_ State/Prov \_\_\_\_\_ Email \_\_\_\_\_

**Application**

Residential New Construction  Residential Geo Replacement  Residential Replacement of Electric, Gas or Other

Multi-Family (Condo/Townhome/Multiplex)  Commercial  Other \_\_\_\_\_

**Use (check all that apply)**

Space Conditioning  Domestic Water Heating  Radiant Heat  Swimming Pool  Snow/Ice Melt

Other \_\_\_\_\_

**Loop Type**

Horizontal Loop  Vertical Loop  Pond Loop  Open Loop

**Demographics**

Household Income  Under \$30,000  \$30,000–\$45,000  \$45,000–\$60,000  \$60,000–\$75,000  \$75,000–\$100,000  Over \$100,000

Home Size  Up to 1500 sq. ft.  1501 to 2500 sq. ft.  2501 to 4000 sq. ft.  Over 4000 sq. ft.

Home Location  Rural  Urban  Suburban

Value of Home  Less than \$100,000  \$100,000–\$250,000  \$250,000–\$500,000  \$500,000–\$1 mil  Over \$1 mil

**Customer Satisfaction**

How would you rate your overall satisfaction with your new geothermal system?

1 (Very Dissatisfied)  2  3  4  5  6  7  8  9  10 (Very Satisfied)

How would you rate your overall satisfaction with your installing geothermal contractor?

1 (Very Dissatisfied)  2  3  4  5  6  7  8  9  10 (Very Satisfied)

**MAIL THIS FORM TO:**  
ENERTECH GLOBAL LLC  
2506 SOUTH ELM STREET  
GREENVILLE, IL 62246

**EMAIL THIS FORM TO:**  
[WARRANTY@ENERTECHGEO.COM](mailto:WARRANTY@ENERTECHGEO.COM)

**FAX THIS FORM TO:**  
ENERTECH GLOBAL LLC  
618.664.4597

**REGISTER ONLINE AT: [warranty-registration.enertechgeo.com](http://warranty-registration.enertechgeo.com)**

Rev 30 DEC 2013B

**This page left blank for Warranty Form detachment.**

## Section 17: Warranty Form and Revision Table

# Revision Table

Date	Note	Page
08MAY2023	PE 90° Street Elbow Discontinued	8
143SEPT2022	Updated for EAD Air Handler match	Various
14MAY2021	Antifreeze Percentages table and Antifreeze Specific Gravity Chart updated.	27
30DEC2019	HE/HR and Pressure Drop Tables added	34
06DEC2019	Unit Electrical Data updated	42
21NOV2019	Document part number changed. 20D085-01NN changed to 20D834-01NN	ALL
03OCT2019	Layout changes made	Various
	AHRI Data Removed	43
14DEC2018	Bi-Flow Solenoid Chart updated. ARS-4A changed to ARS-4B. ARSBK removed.	19, 20, 21
03AUG2017	Updated Fan Chart	-
03NOV2015	Added Air Handler install info and prepared VAF for purchasing	11
29OCT2015	Inserted updated Water Quality table and notes.	All
25FEB2015	Updated nomenclature	4
17NOV2014	Corrected Fan Speed Table	41
11NOV2014	Updated AHRI and Line Set sizes	16, 61
15JUL2014	Updated extended data tables, consolidated nomenclature, warranty registration	4, 64-71
31JUL2013	Added cased "A" coil drawing and dimensions, Superheat/subcooling conditions, three phase wiring diagrams	All
23MAY2013	Updated AHRI Data Tables	6
22OCT2012	Updated Solenoid Coil	35 - 38
21MAY2012	Updated Troubleshooting Data	61 - 65
15MAY2012	Updated Wiring Diagram	51
27APR2012	First published	All



# ENERTECH™

ENERGY + TECHNOLOGY

enertechusa.com



Enertech Global is continually working to improve its products. As a result, the pricing, design and specifications of each product may change without notice and may not be as described herein. For the most up-to-date information, please visit our website, or contact our Customer Service department at [info@enertechgeo.com](mailto:info@enertechgeo.com). Statements and other information contained herein are not express warranties and do not form the basis of any bargain between the parties, but are merely Enertech Global's opinion or commendation of its products.